

(12) INTERNATIONAL APPLICATION PUBLISHED UNDER THE PATENT COOPERATION TREATY (PCT)

(19) World Intellectual Property Organization  
International Bureau



(43) International Publication Date  
22 May 2003 (22.05.2003)

PCT

(10) International Publication Number  
WO 03/042486 A2

- (51) International Patent Classification?: E21B #1004, Carrollton, TX 75006 (US). WADDELL, Kevin, K. [US/US]; 11007 Sprucedale Court, Houston, TX 77070 (US). BRISCO, David, Paul [US/US]; 405 Westridge Drive, Duncan, OK 73533 (US).
- (21) International Application Number: PCT/US02/36157
- (22) International Filing Date: 12 November 2002 (12.11.2002) (74) Agents: MATTINGLY, Todd et al.; Haynes and Boone, LLP, Suite 4300, 1000 Louisiana Street, Houston, TX 77002-5012 (US).
- (25) Filing Language: English
- (26) Publication Language: English (81) Designated States (national): AE, AG, AL, AM, AT, AU, AZ, BA, BB, BG, BR, BY, BZ, CA, CH, CN, CO, CR, CU, CZ, DE, DK, DM, DZ, EC, EE, ES, FI, GB, GD, GE, GH, GM, HR, HU, ID, IL, IN, IS, JP, KE, KG, KP, KR, KZ, LC, LK, LR, LS, LT, LU, LV, MA, MD, MG, MK, MN, MW, MX, MZ, NO, NZ, PL, PT, RO, RU, SD, SE, SG, SI, SK, SL, TJ, TM, TR, TT, TZ, UA, UG, US, UZ, VN, YU, ZA, ZW.
- (30) Priority Data:
  - 60/338,996 12 November 2001 (12.11.2001) US
  - 60/339,013 12 November 2001 (12.11.2001) US
  - 60/363,829 13 March 2002 (13.03.2002) US
  - 60/387,961 12 June 2002 (12.06.2002) US
- (71) Applicant (for all designated States except US): ENVEN- TURE GLOBAL TECHNOLOGY [US/US]; 16200 A. Park Row, Houston, TX 77084 (US).
- (72) Inventors; and
- (75) Inventors/Applicants (for US only): RING, Lev [RU/US]; 14126 Heatherhill Place, Houston, TX 77077 (US). WATSON, Brock [US/US]; 2535 Marsh Lane
- (84) Designated States (regional): ARIPO patent (GH, GM, KE, LS, MW, MZ, SD, SL, SZ, TZ, UG, ZM, ZW), Eurasian patent (AM, AZ, BY, KG, KZ, MD, RU, TJ, TM), European patent (AT, BE, BG, CH, CY, CZ, DE, DK, EE, ES, FI, FR, GB, GR, IE, IT, LU, MC, NL, PT, SE, SK, TR), OAPI patent (BF, BJ, CF, CG, CI, CM, GA, GN, GQ, GW, ML, MR, NE, SN, TD, TG).

[Continued on next page]

(54) Title: COLLAPSIBLE EXPANSION CONE



WO 03/042486 A2

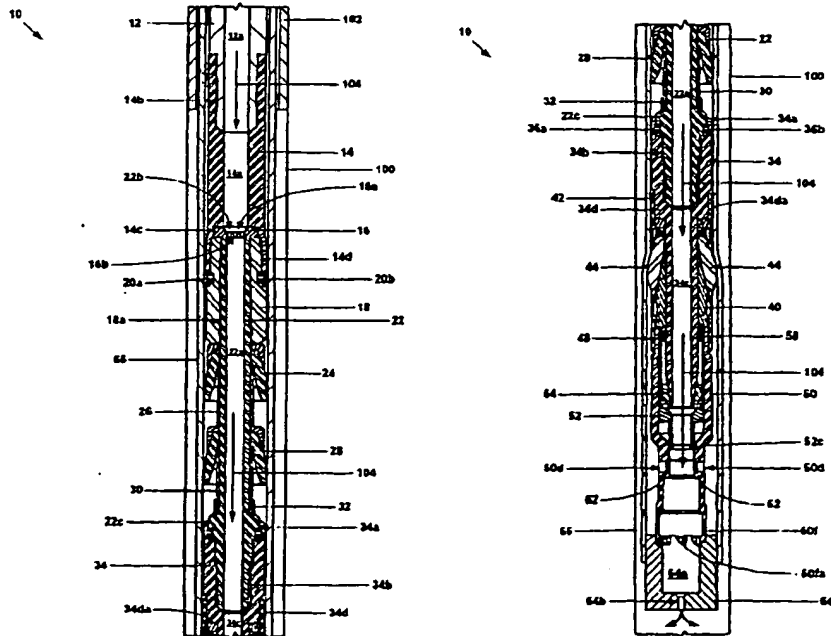

(57) Abstract: An apparatus for radially expanding and plastically an expandable tubular member includes a collapsible expansion cone.

**Declaration under Rule 4.17:**  
— of inventorship (Rule 4.17(iv)) for US only

*For two-letter codes and other abbreviations, refer to the "Guidance Notes on Codes and Abbreviations" appearing at the beginning of each regular issue of the PCT Gazette.*

**Published:**  
*without international search report and to be republished upon receipt of that report*

**COLLAPSIBLE EXPANSION CONE****Cross Reference To Related Applications**

[0001] The present application claims the benefit of the filing dates of: (1) U.S. provisional patent application serial no. 60/338,996, attorney docket no. 25791.87, filed on 11/12/2001, (2) U.S. provisional patent application serial no. 60/339,013, attorney docket no. 88, filed on 11/12/01 (3) U.S. provisional patent application serial no. 60/363,829, attorney docket no. 25791.95, filed on 3/13/2002, and (4) U.S. provisional patent application serial no. 60/387,961, attorney docket no. 25791.108, filed on 6/12/2002, the disclosures of which are incorporated herein by reference.

[0002] The present application is related to the following: (1) U.S. patent application serial no. 09/454,139, attorney docket no. 25791.03.02, filed on 12/3/1999, (2) U.S. patent application serial no. 09/510,913, attorney docket no. 25791.7.02, filed on 2/23/2000, (3) U.S. patent application serial no. 09/502,350, attorney docket no. 25791.8.02, filed on 2/10/2000, (4) U.S. patent no. 6,328,113, (5) U.S. patent application serial no. 09/523,460, attorney docket no. 25791.11.02, filed on 3/10/2000, (6) U.S. patent application serial no. 09/512,895, attorney docket no. 25791.12.02, filed on 2/24/2000, (7) U.S. patent application serial no. 09/511,941, attorney docket no. 25791.16.02, filed on 2/24/2000, (8) U.S. patent application serial no. 09/588,946, attorney docket no. 25791.17.02, filed on 6/7/2000, (9) U.S. patent application serial no. 09/559,122, attorney docket no. 25791.23.02, filed on 4/26/2000, (10) PCT patent application serial no. PCT/US00/18635, attorney docket no. 25791.25.02, filed on 7/9/2000, (11) U.S. provisional patent application serial no. 60/162,671, attorney docket no. 25791.27, filed on 11/1/1999, (12) U.S. provisional patent application serial no. 60/154,047, attorney docket no. 25791.29, filed on 9/16/1999, (13) U.S. provisional patent application serial no. 60/159,082, attorney docket no. 25791.34, filed on 10/12/1999, (14) U.S. provisional patent application serial no. 60/159,039, attorney docket no. 25791.36, filed on 10/12/1999, (15) U.S. provisional patent application serial no. 60/159,033, attorney docket no. 25791.37, filed on 10/12/1999, (16) U.S. provisional patent application serial no. 60/212,359, attorney docket no. 25791.38, filed on 6/19/2000, (17) U.S. provisional patent application serial no. 60/165,228, attorney docket no. 25791.39, filed on 11/12/1999, (18) U.S. provisional patent application serial no. 60/221,443, attorney docket no. 25791.45, filed on 7/28/2000, (19) U.S. provisional patent application serial no. 60/221,645, attorney docket no. 25791.46, filed on 7/28/2000, (20) U.S. provisional patent application serial no. 60/233,638, attorney docket no. 25791.47, filed on 9/18/2000, (21) U.S. provisional patent application serial no. 60/237,334, attorney docket no. 25791.48, filed on 10/2/2000, (22) U.S. provisional patent application serial no. 60/270,007, attorney docket no. 25791.50, filed on 2/20/2001, (23) U.S. provisional patent application serial no. 60/262,434, attorney docket no. 25791.51, filed on 1/17/2001, (24) U.S. provisional patent application serial no. 60/259,486, attorney docket no. 25791.52, filed on 1/3/2001, (25) U.S. provisional patent application serial no. 60/303,740, attorney docket no. 25791.61, filed on 7/6/2001, (26) U.S. provisional patent application serial no. 60/313,453, attorney docket no. 25791.59, filed on 8/20/2001, (27) U.S. provisional patent application serial no. 60/317,985, attorney docket no. 25791.67, filed on 9/6/2001,

(28) U.S. provisional patent application serial no. 60/318,021, attorney docket no. 25791.58, filed on 9/7/2001, (29) U.S. provisional patent application serial no. 60/3318,386, attorney docket no. 25791.67.02, filed on 9/10/2001, (30) U.S. provisional patent application serial no. 60/326,886, attorney docket no. 25791.60, filed on 10/3/2001, (31) U.S. utility patent application serial no. 09/969,922, attorney docket no. 25791.69, filed on 10/3/2001, (32) U.S. provisional patent application serial no. 60/338,996, attorney docket no. 25791.87, filed on 11/12/2001, (33) U.S. provisional patent application serial no. 60/339,013, attorney docket no. 25791.88, filed on 11/12/2001, (34) U.S. utility patent application serial no. 10/016,467, attorney docket no. 25791.70, filed on 12/10/2001, (35) U.S. provisional patent application serial no. 60/343,674, attorney docket no. 25791.68, filed on 12/27/2001, (36) U.S. provisional patent application serial no. 60/346,309, attorney docket no. 25791.92, filed on 1/7/2002, (37) U.S. provisional patent application serial no. 60/357,372, attorney docket no. 25791.71, filed on 2/15/2002, (38) U.S. provisional patent application serial no. 60/363,829, attorney docket no. 25791.95, filed on 3/13/2002, (39) U.S. provisional patent application serial no. 60/372,048, attorney docket no. 25791.93, filed on 4/12/2002, (40) U.S. provisional patent application serial no. 60/372,632, attorney docket no. 25791.101, filed on 4/15/2002, (41) U.S. provisional patent application serial no. 60/380,147, attorney docket no. 25791.104, filed on 5/6/2002, (42) U.S. provisional patent application serial no. 60/383,917, attorney docket no. 25791.89, filed on 5/29/2002, (43) U.S. provisional patent application serial no. 60/387,486, attorney docket no. 25791.107, filed on 6/10/2002, (44) U.S. provisional patent application serial no. 60/387,961, attorney docket no. 25791.108, filed on 6/12/2002, (45) U.S. provisional patent application serial no. 60/391,703, attorney docket no. 25791.90, filed on 6/26/2002, (46) U.S. provisional patent application serial no. 60/397,284, attorney docket no. 25791.106, filed on 7/19/2002, (47) U.S. provisional patent application serial no. 60/398,061, attorney docket no. 25791.110, filed on 7/24/2002, (48) U.S. provisional patent application serial no. 60/399,240, attorney docket no. 25791.111, filed on 7/29/2002, (49) U.S. provisional patent application serial no. 60/405,610, attorney docket no. 25791.119, filed on 8/23/2002, (50) U.S. provisional patent application serial no. 60/405,394, attorney docket no. 25791.120, filed on 8/23/2002, (51) U.S. provisional patent application serial no. 60/407,442, attorney docket no. 25791.125, filed on 8/30/2002, (52) U.S. provisional patent application serial no. 60/412,542, attorney docket no. 25791.102, filed on 9/20/2002, (53) U.S. provisional patent application serial no. 60/412,177, attorney docket no. 25791.117, filed on 9/20/2002, (54) U.S. provisional patent application serial no. 60/412,653, attorney docket no. 25791.118, filed on 9/20/2002, (55) U.S. provisional patent application serial no. 60/412,544, attorney docket no. 25791.121, filed on 9/20/2002, (56) U.S. provisional patent application serial no. 60/412,187, attorney docket no. 25791.128, filed on 9/20/2002, (57) U.S. provisional patent application serial no. 60/412,187, attorney docket no. 25791.127, filed on 9/20/2002, (58) U.S. provisional patent application serial no. 60/412,487, attorney docket no. 25791.112, filed on 9/20/2002, (59) U.S. provisional patent application serial no. 60/412,488, attorney docket no. 25791.114, filed on 9/20/2002, and (60) U.S. provisional patent application serial no. 60/412,371, attorney docket no.

25791.129, filed on 9/20/2002, (61) PCT Patent Application No. PCT/US02\_\_\_\_\_, attorney docket no. 25791.87.02, filed on 11/11/02 and (62) PCT Patent Application No. PCT/US02\_\_\_\_\_, attorney docket no. 25791.88.02, filed on 11/11/02, the disclosures of which are incorporated herein by reference.

#### Background Of The Invention

[0003] This invention relates generally to oil and gas exploration, and in particular to forming and repairing wellbore casings to facilitate oil and gas exploration.

[0004] During oil exploration, a wellbore typically traverses a number of zones within a subterranean formation. Wellbore casings are then formed in the wellbore by radially expanding and plastically deforming tubular members that are coupled to one another by threaded connections. Existing methods for radially expanding and plastically deforming tubular members coupled to one another by threaded connections are not always reliable or produce satisfactory results. In particular, the threaded connections can be damaged during the radial expansion process.

[0005] The present invention is directed to overcoming one or more of the limitations of the existing processes for radially expanding and plastically deforming tubular members coupled to one another by threaded connections.

#### Summary of the Invention

[0006] According to one aspect of the present invention, an apparatus for radially expanding and plastically deforming an expandable tubular member is provided that includes an upper tubular support member defining a first passage, one or more cup seals coupled to the exterior surface of the upper tubular support member for sealing an interface between the upper tubular support member and the expandable tubular member, an upper cam assembly coupled to the upper tubular support member comprising: a tubular base coupled to the upper tubular support member, and a plurality of cam arms extending from the tubular base in a downward longitudinal direction, each cam arm defining an inclined surface, a plurality of upper expansion cone segments interleaved with the cam arms of the upper cam assembly and pivotally coupled to the tubular support member, a lower tubular support member defining a second passage fluidically coupled to the first passage releasably coupled to the upper tubular support member, and a lower cam assembly coupled to the lower tubular support member comprising: a tubular base coupled to the lower tubular support member, and a plurality of cam arms extending from the tubular base in an upward longitudinal direction, each cam arm defining an inclined surface that mates with the inclined surface of a corresponding one of the upper expansion cone segments, wherein the cam arms of the upper cam assembly are interleaved with and overlap the cam arms of the lower cam assembly, a plurality of lower expansion cone segments interleaved with cam arms of the lower cam assembly, each lower expansion cone segment pivotally coupled to the lower tubular support member and mating with the inclined surface of a corresponding one of the cam arms of the upper cam assembly, wherein the lower expansion cone segments interleave and overlap the upper expansion cone segments, and wherein the upper and lower expansion cone segments together define an

arcuate spherical external surface for plastically deforming and radially expanding the expandable tubular member.

[0007] According to another aspect of the present invention, a collapsible expansion cone assembly is provided that includes an upper tubular support member comprising an internal flange, an upper cam assembly coupled to the upper tubular support member comprising: a tubular base coupled to the upper support member, and a plurality of cam arms extending from the tubular base in a downward longitudinal direction, each cam arm defining an inclined surface, a plurality of upper expansion cone segments interleaved with the cam arms of the upper cam assembly and pivotally coupled to the internal flange of the upper tubular support member, a lower tubular support member comprising an internal flange, one or more frangible couplings for releasably coupling the upper and lower tubular support members, a lower cam assembly coupled to the lower tubular support member comprising: a tubular base coupled to the lower tubular support member, and a plurality of cam arms extending from the tubular base in an upward longitudinal direction, each cam arm defining an inclined surface that mates with the inclined surface of a corresponding one of the upper expansion cone segments, wherein the cam arms of the upper cam assembly are interleaved with and overlap the cam arms of the lower cam assembly, and a plurality of lower expansion cone segments interleaved with cam arms of the lower cam assembly, each lower expansion cone segment pivotally coupled to the internal flange of the lower tubular support member and mating with the inclined surface of a corresponding one of the cam arms of the upper cam assembly, wherein the lower expansion cone segments interleave and overlap the upper expansion cone segments, and wherein the upper and lower expansion cone segments together define an arcuate spherical external surface for plastically deforming and radially expanding the expandable tubular member.

[0008] According to another aspect of the present invention, an apparatus for radially expanding and plastically deforming an expandable tubular member is provided that includes a tubular support member, a collapsible expansion cone coupled to the tubular support member, an expandable tubular member coupled to the collapsible expansion cone, means for displacing the collapsible expansion cone relative to the expandable tubular member, and means for collapsing the expansion cone.

[0009] According to another aspect of the present invention, a collapsible expansion cone is provided that includes an upper cam assembly comprising: a tubular base, and a plurality of cam arms extending from the tubular base in a downward longitudinal direction, each cam arm defining an inclined surface, a plurality of upper expansion cone segments interleaved with the cam arms of the upper cam assembly, a lower cam assembly comprising: a tubular base, and a plurality of cam arms extending from the tubular base in an upward longitudinal direction, each cam arm defining an inclined surface that mates with the inclined surface of a corresponding one of the upper expansion cone segments, wherein the cam arms of the upper cam assembly are interleaved with and overlap the cam arms of the lower cam assembly, a plurality of lower expansion cone segments interleaved with cam arms of the lower cam assembly, each lower expansion cone segment mating with the inclined surface

of a corresponding one of the cam arms of the upper cam assembly, means for moving the upper cam assembly away from the lower expansion cone segments, and means for moving the lower cam assembly away from the upper expansion cone segments.

[00010] According to another aspect of the invention, an apparatus for radially expanding and plastically deforming an expandable tubular member is provided that includes a tubular support member, a collapsible expansion cone coupled to the tubular support member, an expandable tubular member coupled to the collapsible expansion cone, means for displacing the collapsible expansion cone relative to the expandable tubular member, and means for collapsing the expansion cone.

[0010] According to another aspect of the invention, a collapsible expansion cone is provided that includes an upper cam assembly comprising: a tubular base, and a plurality of cam arms extending from the tubular base in a downward longitudinal direction, each cam arm defining an inclined surface, a plurality of upper expansion cone segments interleaved with the cam arms of the upper cam assembly, a lower cam assembly comprising: a tubular base, and a plurality of cam arms extending from the tubular base in an upward longitudinal direction, each cam arm defining an inclined surface that mates with the inclined surface of a corresponding one of the upper expansion cone segments, wherein the cam arms of the upper cam assembly are interleaved with and overlap the cam arms of the lower cam assembly, a plurality of lower expansion cone segments interleaved with cam arms of the lower cam assembly, each lower expansion cone segment mating with the inclined surface of a corresponding one of the cam arms of the upper cam assembly, means for moving the upper cam assembly away from the lower expansion cone segments, and means for moving the lower cam assembly away from the upper expansion cone segments.

[0011] According to another aspect of the invention, a method of radially expanding and plastically deforming an expandable tubular member is provided that includes supporting the expandable tubular member using a tubular support member and a collapsible expansion cone, injecting a fluidic material into the tubular support member, sensing the operating pressure of the injected fluidic material within a first interior portion of the tubular support member, displacing the collapsible expansion cone relative to the expandable tubular member when the sensed operating pressure of the injected fluidic material exceeds a predetermined level within the first interior portion of the tubular support member, sensing the operating pressure of the injected fluidic material within a second interior portion of the tubular support member, and collapsing the collapsible expansion cone when the sensed operating pressure of the injected fluidic material exceeds a predetermined level within the second interior portion of the tubular support member.

#### Brief Description of the Drawings

[0012] Fig. 1a is a fragmentary cross-sectional illustration of the placement of a portion of an exemplary embodiment of an apparatus for radially expanding and plastically deforming a tubular member that includes a collapsible expansion cone within a preexisting structure.

- [0013] Fig. 1b is a fragmentary cross-sectional illustration of another portion of the apparatus of Fig. 1a.
- [0014] Figs. 2a and 2b are fragmentary cross-sectional illustration of a portion of the apparatus of Figs. 1a and 1b.
- [0015] Fig. 3 is a fragmentary cross-sectional illustration of a portion of the apparatus of Figs. 1a and 1b.
- [0016] Fig. 3a is a fragmentary cross-sectional illustration of a portion of the apparatus of Fig 3.
- [0017] Fig. 3b is a fragmentary cross-sectional illustration of a portion of the apparatus of Fig 3.
- [0018] Fig. 4 is a fragmentary cross-sectional illustration of a portion of the apparatus of Figs. 1a and 1b.
- [0019] Fig. 4a is a fragmentary cross-sectional illustration of a portion of the apparatus of Fig 4.
- [0020] Fig. 5 is a fragmentary cross-sectional illustration of a portion of the apparatus of Figs. 1a and 1b.
- [0021] Fig. 6 is a fragmentary cross-sectional illustration of a portion of the apparatus of Figs. 1a and 1b.
- [0022] Figs. 7a-7e are fragmentary cross-sectional and perspective illustrations of the upper cam assembly of the apparatus of Figs. 1a and 1b.
- [0023] Fig. 7f is a fragmentary cross-sectional illustration of the lower cam assembly of the apparatus of Figs. 1a and 1b.
- [0024] Figs. 8a-8d are fragmentary cross-sectional and perspective illustrations of one of the upper cone segments of the apparatus of Figs. 1a and 1b.
- [0025] Fig. 8e is a fragmentary cross-sectional illustration of one of the lower cone segments of the apparatus of Figs. 1a and 1b.
- [0026] Fig. 9 is a side view of a portion of the apparatus of Figs. 1a and 1b.
- [0027] Fig. 10a is a fragmentary cross sectional illustration of a portion of the apparatus of Figs. 1a and 1b during the radial expansion of the expandable tubular member.
- [0028] Fig. 10b is a fragmentary cross sectional illustration of another portion of the apparatus of Fig. 10a.
- [0029] Fig. 11a. is a fragmentary cross sectional illustration of a portion of the apparatus of Figs. 10a and 10b during the adjustment of the expansion cone to a collapsed position.
- [0030] Fig. 11b is a fragmentary cross sectional illustration of another portion of the apparatus of Fig. 11a.
- [0031] Fig. 12 is a fragmentary cross sectional illustration of a portion of the apparatus of Figs. 11a and 11b.
- [0032] Fig. 13 is a fragmentary cross sectional illustration of a portion of the apparatus of Figs. 11a and 11b.



- [0033] FIG. 14 is a fragmentary cross sectional illustration of a portion of the apparatus of Figs. 11a and 11b with the expansion cone in a half collapsed position.
- [0034] FIG. 15 is a fragmentary cross sectional illustration of a portion of the apparatus of Figs. 11a and 11b with the expansion cone in a fully collapsed position.
- [0035] Fig. 16 is a side view of a portion of the apparatus of Figs. 10a and 10b.
- [0036] Fig. 17a. is a fragmentary cross sectional illustration of a portion of the apparatus of Figs. 11a and 11b after the removal of the apparatus from interior of the expandable tubular member.
- [0037] Fig. 17b is a fragmentary cross sectional illustration of another portion of the apparatus of Fig. 17a.

#### Detailed Description of the Illustrative Embodiments

- [0038] Referring to Figs. 1a, 1b, 2a, 2b, 3, 3a, 4, 4a, 5, 6, 7a, 7b, 7c, 7d, 7e, 7f, 8a, 8b, 8c, 8d, 8e, and 9, an exemplary embodiment of an apparatus 10 for radially expanding and plastically deforming a tubular member includes a tubular support member 12 that defines a passage 12a. An end of the tubular support member 12 is coupled to an end of a safety collar 14 that defines a passage 14a, a recess 14b at one end for receiving the end of the tubular support member, and recesses 14c and 14d at another end.
- [0039] A torque plate 16 is received within and is coupled to the recess 14c of the safety collar 14 that defines a passage 16a and a plurality of meshing teeth 16b at one end. An end of an upper mandrel collar 18 is received with and is coupled to the recess 14d of the safety collar 14 proximate and end of the torque plate 16 that defines a passage 18a. Torque pins 20a and 20b further couple the end of the upper mandrel collar 18 to the end of the safety collar 14.
- [0040] An end of an upper mandrel 22 is received within and is coupled to the upper mandrel collar 18 that defines a passage 22a, a plurality of meshing teeth 22b that mate with and transmit torque to and from the meshing teeth 16b of the torque plate 16, and an external flange 22c at another end.
- [0041] An upper packer cup 24 mates with, receives and is coupled to the upper mandrel 22 proximate the end of the upper mandrel collar 18. In an exemplary embodiment, the upper packer cup 24 is a Guiberson™ packer cup. An upper spacer sleeve 26 mates with, receives, and is coupled to the upper mandrel 22 proximate an end of the upper packer cup 24. A lower packer cup 28 mates with, receives and is coupled to the upper mandrel 22 proximate an end of the upper spacer sleeve 26. In an exemplary embodiment, the lower packer cup 28 is a Guiberson™ packer cup. A lower spacer sleeve 30 mates with, receives, and is coupled to the upper mandrel 22 proximate an end of the lower packer cup 28 and the external flange 22c of the upper mandrel. A retaining sleeve 32 mates with, receives, and is coupled to an end of the lower spacer sleeve proximate the external flange 22c of the upper mandrel 22.
- [0042] An end of a lower mandrel 34 defines a recess 34a that mates with, receives, and is coupled to the external flange 22c of the upper mandrel 22, a recess 34b that mates with, receives, and is coupled to the end of the upper mandrel, a passage 34c, and an external flange 34d including circumferentially spaced apart meshing teeth 34da on an end face of the external flange. Torque pins

36a and 36b further couple the recess 34a of the end of the lower mandrel 34 to the external flange 22c of the upper mandrel 22. During operation, the torque pins 36a and 36b transmit torque loads between the recess 34a of the end of the lower mandrel 34 and the external flange 22c of the upper mandrel 22.

[0043] An upper cam assembly 38 includes a tubular base 38a for receiving and mating with the lower mandrel 34 that includes an external flange 38aa, a plurality of circumferentially spaced apart meshing teeth 38b that extend from one end of the tubular base in the longitudinal and radial directions for engaging the meshing teeth 34da of the end face of the external flange 34d of the lower mandrel, and a plurality of circumferentially spaced apart cam arms 38c that extend from the other end of the tubular base in the opposite longitudinal direction and mate with and receive the lower mandrel. During operation, the meshing teeth 34da of the end face of the external flange 34d of the lower mandrel 34 transmit torque loads to the meshing teeth 38b of the upper cam assembly 38. Each of the cam arms 38c include an inner portion 38ca extending from the tubular base 38a that has arcuate cylindrical inner and outer surfaces, 38caa and 38cab, a tapered intermediate portion 38cb extending from the inner portion that has an arcuate cylindrical inner surface 38cba and an arcuate conical outer surface 38cbb, and an outer portion 38cc extending from the intermediate portion that has arcuate cylindrical inner and outer surfaces, 38cca and 38ccb. In an exemplary embodiment, the radius of curvatures of the arcuate outer cylindrical surfaces 38cab are greater than the radius of curvatures of the arcuate outer cylindrical surfaces 38ccb. In an exemplary embodiment, the radius of curvatures of the arcuate inner cylindrical surfaces, 38caa, 38cba, and 38cca are equal.

[0044] A lower cam assembly 40 includes a tubular base 40a for receiving and mating with the lower mandrel 34 that includes an external flange 40aa, a plurality of circumferentially spaced apart meshing teeth 40b that extend from one end of the tubular base in the longitudinal and radial directions, and a plurality of circumferentially spaced apart cam arms 40c that extend from the other end of the tubular base in the opposite longitudinal direction and mate with and receive the lower mandrel. Each of the cam arms 40c include an inner portion 40ca extending from the tubular base 40a that has arcuate cylindrical inner and outer surfaces, 40caa and 40cab, a tapered intermediate portion 40cb extending from the inner portion 40ca that has an arcuate cylindrical inner surface 40cba and an arcuate conical outer surface 40cbb, and an outer portion 40cc extending from the intermediate portion that has arcuate cylindrical inner and outer surfaces, 40cca and 40ccb. In an exemplary embodiment, the radius of curvatures of the arcuate outer cylindrical surfaces 40cab are greater than the radius of curvatures the arcuate outer cylindrical surfaces 40ccb. In an exemplary embodiment, the radius of curvatures of the arcuate inner cylindrical surfaces, 40caa, 40cba, and 40cca are equal. In an exemplary embodiment, the upper and lower cam assemblies, 38 and 40, are substantially identical. In an exemplary embodiment, the cam arms 38c of the upper cam assembly 38 interleave the cam arms 40c of the lower cam assembly 40. Furthermore, in an exemplary embodiment, the cam arms 38c of the upper cam assembly also overlap with the cam arms 40c of the lower cam assembly 40 in the longitudinal direction thereby permitting torque loads to be transmitted between the upper and lower cam assemblies.

[0045] An end of an upper retaining sleeve 42 receives and is threadably coupled to the external flange 34d of the lower mandrel 34 that defines a passage 42a for receiving and mating with the outer circumferential surfaces of the external flange 38aa and the meshing teeth 38b of the upper cam assembly 38, and an inner annular recess 42b, and includes an internal flange 42c for retaining the external flange 38aa of the upper cam assembly, and an internal flange 42d at one end of the upper retaining sleeve that includes a rounded interior end face. An o-ring seal 44 is received within the annular recess 42b for sealing the interface between the upper retaining sleeve 42 and the external flange 34d of the lower mandrel 34. A disc shaped shim 43 is positioned within the upper retaining sleeve 42 between the opposing end faces of the internal flange 42c of the retaining sleeve and the meshing teeth 38b of the upper cam assembly 38.

[0046] A plurality of upper expansion cone segments 44 are interleaved among the cam arms 38c of the upper cam assembly 38. Each of the upper expansion cone segments 44 include inner portions 44a having arcuate cylindrical inner surfaces, 44aaa and 44aab, and an arcuate cylindrical outer surface 44ab, intermediate portions 44b extending from the interior portions that have an arcuate conical inner surface 44ba and arcuate cylindrical and spherical outer surfaces, 44bba and 44bbh, and outer portions 44c having arcuate cylindrical inner and outer surfaces, 44ca and 44cb. In an exemplary embodiment, the outer surfaces 44ab of the inner portions 44a of the upper expansion cone segments define hinge grooves 44aba that receive and are pivotally mounted upon the internal flange 42d of the upper retaining sleeve 42.

[0047] The arcuate inner cylindrical surfaces 44aaa mate with and receive the lower mandrel 34, the arcuate inner cylindrical surfaces 44aab mate with and receive the arcuate cylindrical outer surfaces 40ccb of the outer portions 40cc of the corresponding cam arms 40c of the lower cam assembly 40, and the arcuate inner conical surfaces 44ba mate with and receive the arcuate conical outer surfaces 40cbb of the intermediate portions 40cb of the corresponding cam arms of the lower cam assembly.

[0048] In an exemplary embodiment, the radius of curvature of the arcuate cylindrical inner surface 44aaa is less than the radius of curvature of the arcuate cylindrical inner surface 44aab. In an exemplary embodiment, the radius of curvature of the arcuate cylindrical inner surface 44ca is greater than the radius of curvature of the arcuate cylindrical surface 44aab. In an exemplary embodiment, the arcuate cylindrical inner surfaces, 44aaa and 44aab, are parallel. In an exemplary embodiment, the arcuate cylindrical outer surface 44ab is inclined relative to the arcuate cylindrical inner surface 44aaa. In an exemplary embodiment, the arcuate cylindrical outer surface 44bba is parallel to the arcuate cylindrical inner surfaces, 44aaa and 44aab. In an exemplary embodiment, the arcuate cylindrical outer surface 44cb is inclined relative to the arcuate cylindrical inner surface 44ca.

[0049] A plurality of lower expansion cone segments 46 are interleaved among, and overlap, the upper expansion cone segments 44 and the cam arms 38c of the lower cam assembly 38. In this manner, torque loads may be transmitted between the upper and lower expansion cone segments, 44 and 46. Each of the lower expansion cone segments 46 include inner portions 46a having arcuate

cylindrical inner surfaces, 46aaa and 46aab, and an arcuate cylindrical outer surface 46ab, intermediate portions 46b extending from the interior portions that have an arcuate conical inner surface 46ba and arcuate cylindrical and spherical outer surfaces, 46bba and 46bbb, and outer portions 46c having arcuate cylindrical inner and outer surfaces, 46ca and 46cb. In an exemplary embodiment, the outer surfaces 46ab of the inner portions 46a of the upper expansion cone segments 46 define hinge grooves 46aba.

[0050] The arcuate inner cylindrical surfaces 46aaa mate with and receive the lower mandrel 34, the arcuate inner cylindrical surfaces 46aab mate with and receive the arcuate cylindrical outer surfaces 38ccb of the outer portions 38cc of the corresponding cam arms 38c of the upper cam assembly 38, and the arcuate inner conical surfaces 46ba mate with and receive the arcuate conical outer surfaces 38cbb of the intermediate portions 38cb of the corresponding cam arms of the lower cam assembly.

[0051] In an exemplary embodiment, the radius of curvature of the arcuate cylindrical inner surface 46aaa is less than the radius of curvature of the arcuate cylindrical inner surface 46aab. In an exemplary embodiment, the radius of curvature of the arcuate cylindrical inner surface 46ca is greater than the radius of curvature of the arcuate cylindrical surface 46aab. In an exemplary embodiment, the arcuate cylindrical inner surfaces, 46aaa and 46aab, are parallel. In an exemplary embodiment, the arcuate cylindrical outer surface 46ab is inclined relative to the arcuate cylindrical inner surface 46aaa. In an exemplary embodiment, the arcuate cylindrical outer surface 46bba is parallel to the arcuate cylindrical inner surfaces, 46aaa and 46aab. In an exemplary embodiment, the arcuate cylindrical outer surface 46cb is inclined relative to the arcuate cylindrical inner surface 46ca.

[0052] In an exemplary embodiment, the geometries of the upper and lower expansion cone segments 44 and 46 are substantially identical. In an exemplary embodiment, the upper expansion cone segments 44 are tapered in the longitudinal direction from the ends of the intermediate portions 44b to the ends of the outer portions 44c, and the lower expansion cone segments 46 are tapered in the longitudinal direction from the ends of the intermediate portions 46b to the ends of the outer portions 46c. In an exemplary embodiment, when the upper and lower expansion segments, 44 and 46, are positioned in a fully expanded position, the arcuate cylindrical outer surfaces, 44bba and 46cb, of the upper and lower expansion cone segments define a contiguous cylindrical surface, the arcuate spherical outer surfaces, 44bbb and 46bbb, of the upper and lower expansion cone segments define an contiguous arcuate spherical surface, and the arcuate cylindrical outer surfaces, 44cb and 46bba, of the upper and lower expansion cone segments define a contiguous cylindrical surface.

[0053] An end of a lower retaining sleeve 48 defines a passage 48a for receiving and mating with the outer circumferential surfaces of the external flange 40aa and the meshing teeth 40b of the lower cam assembly 40, and an inner annular recess 48b, and includes an internal flange 48c for retaining the external flange of the lower cam assembly, and an internal flange 48d at one end of the lower retaining sleeve that includes a rounded interior end face for mating with the hinge grooves 46 aba of the lower expansion cone segments 46 thereby pivotally coupling the lower expansion cone segments to the lower

retaining sleeve. An o-ring seal 50 is received within the annular recess 48b. A disc shaped shim 49 is positioned within the lower retaining sleeve 48 between the opposing end faces of the internal flange 48c of the retaining sleeve and the external flange 40aa of the lower cam assembly 40.

[0054] In an exemplary embodiment, the arcuate cylindrical outer surfaces 44bba of the upper expansion cone segments 44 and the arcuate cylindrical outer surfaces 46cb of the lower expansion cone segments 46 are aligned with the outer surface of the upper retaining sleeve 42. In an exemplary embodiment, the arcuate cylindrical outer surfaces 44cb of the upper expansion cone segments 44 and the arcuate cylindrical outer surfaces 46 bba of the lower expansion cone segments are aligned with the outer surface of the lower retaining sleeve 48.

[0055] An end of a float shoe adaptor 50 that includes a plurality of circumferentially spaced apart meshing teeth 50a for engaging the meshing teeth 40b of the lower cam assembly 40 is received within and threadably coupled to an end of the lower retaining sleeve 48 that defines a passage 50b at one end for receiving an end of the lower mandrel 34, a passage 50c having a reduced inside diameter at another end, a plurality of radial passages 50d at the other end, and includes an internal flange 50e, and a torsional coupling 50f at the other end that includes a plurality of torsional coupling members 50fa. During operation, the meshing teeth 40b of the lower cam assembly 40 transmit torque loads to and from the meshing teeth 50a of the float shoe adaptor.

[0056] An end of a retaining sleeve 52 abuts the end face of the tubular base 40a of the lower cam assembly 40 and is received within and mates with the passage 50b of the float shoe adaptor 50 that defines a passage 52a for receiving an end of the lower mandrel 34, a throat passage 52b including a ball valve seat 52c, and includes a flange 52d, and another end of the retaining sleeve, having a reduced outside diameter, is received within and mates with the passage 50c of the float shoe adaptor 50.

[0057] A stop nut 54 receives and is threadably coupled to the end of the lower mandrel 34 within the passage 52a of the retaining sleeve 52, and shear pins 56 releasably couple the stop nut 54 to the retaining sleeve 52. Locking dogs 58 are positioned within an end of the retaining sleeve 52 that receive and are releasably coupled to the lower mandrel 34, and a disc shaped adjustment shim 60 receives the lower mandrel 34 and is positioned within an end of the retaining sleeve 52 between the opposing ends of the tubular base 40a of the upper cam assembly 40 and the locking dogs 58. Burst discs 62 are releasably coupled to and positioned within the radial passages 50d of the float shoe adaptor 50.

[0058] An end of a float shoe 64 mates with and is releasably coupled to the torsional coupling members 50fa of the torsional coupling 50f of the float shoe adaptor 50 that defines a passage 64a and a valveable passage 64b. In this manner torsional loads may be transmitted between the float shoe adaptor 50 and the float shoe 64. An end of an expandable tubular member 66 that surrounds the tubular support member 12, the safety collar 14, the upper mandrel collar 18, the upper packer cup 24, the lower packer cup 28, the lower mandrel 34, the upper expansion cone segments 44, the lower expansion cone segments 46, and the float shoe adaptor 50, is coupled to and receives an end of the

float shoe 64 and is movably coupled to and supported by the arcuate spherical external surfaces, 44bbb and 46bbb, of the upper and lower expansion cone segments, 44 and 46.

[0059] During operation, as illustrated in Figs. 1a and 1b, the apparatus 10 is at least partially positioned within a preexisting structure such as, for example, a borehole 100 that traverses a subterranean formation that may include a preexisting wellbore casing 102. The borehole 100 may be oriented in any position, for example, from vertical to horizontal. A fluidic material 104 is then injected into the apparatus 10 through the passages 12a, 14a, 22a, 34c, 50c, 64a, and 64b into the annulus between the expandable tubular member 66 and the borehole 100. In an exemplary embodiment, the fluidic material 104 is a hardenable fluidic sealing material. In this manner, an annular sealing layer may be formed within the annulus between the expandable tubular member 66 and the borehole 100.

[0060] As illustrated in Figs. 10a and 10b, a ball 106 is then be positioned within and blocking the valveable passage 64b of the float shoe 64 by injecting a fluidic material 108 into the apparatus 10 through the passages 12a, 14a, 22a, 34c, and 50c. As a result, the increased operating pressure within the passage 50c bursts open the burst discs 62 positioned within the radial passages 50d of the float shoe adaptor 50. The continued injection of the fluidic material 108 thereby pressurizes the interior of the expandable tubular member 66 below the lower packer cup 28 thereby displacing the upper and lower expansion cone segments, 44 and 46, upwardly relative to the float shoe 64 and the expandable tubular member 66. As a result, the expandable tubular member 66 is plastically deformed and radially expanded. Thus, the burst discs 62 sense the operating pressure of the injected fluidic material 108 within the passage 50c and thereby control the initiation of the radial expansion and plastic deformation of the expandable tubular member 66.

[0061] In an exemplary embodiment, any leakage of the pressurized fluidic material 108 past the lower packer cup 28 is captured and sealed against further leakage by the upper packer cup 24. In this manner, the lower packer cup 28 provides the primary fluidic seal against the interior surface of the expandable tubular member 66, and the upper packer cup 24 provides a secondary, back-up, fluidic seal against the interior surface of the expandable tubular member. Furthermore, because the lower packer cup 28 and/or the upper packer cup 24 provide a fluid tight seal against the interior surface of the expandable tubular member 66, the upper and lower expansion cone segments, 44 and 46, are pulled upwardly through the expandable tubular member by the axial forces created by the packer cups.

[0062] In an exemplary embodiment, during the radial expansion process, the interface between the arcuate spherical external surfaces, 44bbb and 46bbb, of the upper and lower expansion cone segments, 44 and 46, and the interior surface of the expandable tubular member 66 is not fluid tight. As a result, the fluidic material 108 may provide lubrication to the entire extent of the interface between the cylindrical external surfaces, 44bba and 46cb, and the arcuate spherical external surfaces, 44bbb and 46bbb, of the upper and lower expansion cone segments, 44 and 46, and the interior surface of the expandable tubular member 66. Moreover, experimental test results have indicated the unexpected result that the required operating pressure of the fluidic material 108 for radial expansion of the

expandable tubular member 66 is less when the interface between the cylindrical external surfaces, 44bba and 46cb, and the arcuate spherical external surfaces, 44bbb and 46bbb, of the upper and lower expansion cone segments, 44 and 46, and the interior surface of the expandable tubular member 66 is not fluid tight. Furthermore, experimental test results have also demonstrated that the arcuate spherical external surface provided by the arcuate spherical external surfaces, 44bbb and 46bbb, of the upper and lower expansion cone segments, 44 and 46, provides radial expansion and plastic deformation of the expandable tubular member 66 using lower operating pressures versus an expansion cone having a conical outer surface.

[0063] In an exemplary embodiment, as illustrated in Figs. 11a, 11b, 12, 13, 14, 15, and 16, the upper and lower expansion cone segments, 44 and 46, may then be adjusted to a collapsed position by placing a ball 110 within the ball valve seat 52c of the throat passage 52b of the retaining sleeve 52. The continued injection of the fluidic material 108, after the placement of the ball 110 within the ball valve seat 52c, creates a differential pressure across the ball 110 thereby applying a downward longitudinal force onto the retaining sleeve 52 thereby shearing the shear pins 56. As a result, the retaining sleeve 52 is displaced in the downward longitudinal direction relative to the float shoe adaptor 50 thereby permitting the locking dogs 58 to be displaced outwardly in the radial direction. The outward radial displacement of the locking dogs 58 disengages the locking dogs from engagement with the lower mandrel 34. Thus, the shear pins 56 sense the operating pressure of the injected fluidic material 108 within the throat passage 52b and thereby controlling the initiation of the collapsing of the upper and lower expansion cone segments, 44 and 46.

[0064] The continued injection of the fluidic material 108 continues to displace the retaining sleeve 52 in the downward longitudinal direction relative to the float shoe adaptor 50 until the external flange 52d of the retaining sleeve 52 impacts, and applies a downward longitudinal force to, the internal flange 50e of the float shoe adaptor. As a result, the float shoe adaptor 50 is then also displaced in the downward longitudinal direction relative to the lower mandrel 34. The downward longitudinal displacement of the float shoe adaptor 50 relative to the lower mandrel 34 causes the lower cam assembly 40, the lower expansion cone segments 46, and the lower retaining sleeve 48, which are rigidly attached to the float shoe adaptor, to also be displaced downwardly in the longitudinal direction relative to the lower mandrel 34, the upper cam assembly 38, and the upper expansion cone segments 44.

[0065] The downward longitudinal displacement of the lower cam assembly 40 relative to the upper expansion cone segments 44 causes the upper expansion cone segments to slide off of the conical external surfaces 40cbb of the lower cam assembly and thereby pivot inwardly in the radial direction about the internal flange 42d of the upper retaining sleeve 42. The downward longitudinal displacement of the lower expansion cone segments 46 relative to the upper cam assembly 38 causes the lower expansion cone segments 46 to slide off of the external conical surfaces 38cbb of the upper cam assembly and thereby pivot inwardly in the radial direction about the internal flange 48d of the

lower retaining sleeve. As a result of the inward radial movement of the upper and lower expansion cone segments, 44 and 46, the arcuate external spherical surfaces, 44bbb and 46bbb, of the upper and lower expansion cone segments, 44 and 46, no longer provide a substantially contiguous outer arcuate spherical surface.

[0066] The downward longitudinal movement of the retaining sleeve 42 and float shoe adaptor 50 relative to the lower mandrel 34 is stopped when the stop nut 54 impacts the locking dogs 58. At this point, as illustrated in Figs. 17a and 17b, the apparatus 10 may then be removed from the interior of the expandable tubular member 66.

[0067] Thus, the apparatus 10 may be removed from the expandable tubular member 66 prior to the complete radial expansion and plastic deformation of the expandable tubular member by controllably collapsing the upper and lower expansion cone segments, 44 and 46. As a result, the apparatus 10 provides the following benefits: (1) the apparatus is removable when expansion problems are encountered; (2) lower expansion forces are required because the portion of the expandable tubular member 66 between the packer cups, 24 and 28, and the expansion cone segments is exposed to the expansion fluid pressure; and (3) the expansion cone segments can be run down through the expandable tubular member, prior to radial expansion, and then the expansion cone segments can be expanded.

[0068] In several alternative embodiments, resilient members such as, for example, spring elements are coupled to the upper and lower expansion cone segments, 44 and 46, for resiliently biasing the expansion cone segments towards the expanded or collapsed position.

[0069] In several alternative embodiments, the placement of the upper and lower expansion cone segments, 44 and 46, in an expanded or collapsed position is reversible as disclosed in PCT patent application serial no. PCT/\_\_\_\_\_/\_\_\_\_\_, attorney docket no. 25791.88.02, filed on \_\_\_\_\_, the disclosure of which is incorporated herein by reference.

[0070] In several alternative embodiments, a small gap is provided between the upper and lower expansion cone segments, 44 and 46, when positioned in the expanded condition that varies from about .005 to .030 inches.

[0071] An apparatus for radially expanding and plastically deforming an expandable tubular member has been described that includes an upper tubular support member defining a first passage, one or more cup seals coupled to the exterior surface of the upper tubular support member for sealing an interface between the upper tubular support member and the expandable tubular member, an upper cam assembly coupled to the upper tubular support member comprising: a tubular base coupled to the upper tubular support member, and a plurality of cam arms extending from the tubular base in a downward longitudinal direction, each cam arm defining an inclined surface, a plurality of upper expansion cone segments interleaved with the cam arms of the upper cam assembly and pivotally coupled to the tubular support member, a lower tubular support member defining a second passage fluidically coupled to the first passage releasably coupled to the upper tubular support member, a lower cam assembly coupled to the lower tubular support member comprising: a tubular base coupled to the lower tubular support



member, and a plurality of cam arms extending from the tubular base in an upward longitudinal direction, each cam arm defining an inclined surface that mates with the inclined surface of a corresponding one of the upper expansion cone segments, wherein the cam arms of the upper cam assembly are interleaved with and overlap the cam arms of the lower cam assembly, and a plurality of lower expansion cone segments interleaved with cam arms of the lower cam assembly, each lower expansion cone segment pivotally coupled to the lower tubular support member and mating with the inclined surface of a corresponding one of the cam arms of the upper cam assembly, wherein the lower expansion cone segments interleave and overlap the upper expansion cone segments, and wherein the upper and lower expansion cone segments together define an arcuate spherical external surface for plastically deforming and radially expanding the expandable tubular member. In an exemplary embodiment, the upper tubular support member includes: a safety collar, a torque plate coupled to the safety collar including a plurality of circumferentially spaced apart meshing teeth at an end, an upper mandrel including a plurality of circumferentially spaced apart meshing teeth at one end for engaging the meshing teeth of the torque plate and an external flange at another end, and a lower mandrel coupled to the external flange of the upper mandrel including an external flange including a plurality of circumferentially spaced apart meshing teeth. In an exemplary embodiment, the tubular base of the upper cam assembly includes a plurality of circumferentially spaced apart meshing teeth for engaging the meshing teeth of the external flange of the lower mandrel. In an exemplary embodiment, the apparatus further includes a stop nut coupled to an end of the lower mandrel for limiting the movement of the lower tubular member relative to the lower mandrel. In an exemplary embodiment, the apparatus further includes locking dogs coupled to the lower mandrel. In an exemplary embodiment, the lower tubular support member includes: a float shoe adapter including a plurality of circumferentially spaced apart meshing teeth at one end, an internal flange, and a torsional coupling at another end, a lower retaining sleeve coupled to an end of the float shoe adapter including an internal flange for pivotally engaging the lower expansion cone segments, and a retaining sleeve received within the float shoe adapter releasably coupled to the upper tubular support member. In an exemplary embodiment, an end of the retaining sleeve abuts an end of the tubular base of the lower cam assembly. In an exemplary embodiment, the tubular base of the lower cam assembly includes a plurality of circumferentially spaced apart meshing teeth for engaging the meshing teeth of the float shoe adapter. In an exemplary embodiment, the apparatus further includes a float shoe releasably coupled to the torsional coupling of the float shoe adapter, and an expandable tubular member coupled to the float shoe and supported by and movably coupled to the upper and lower expansion cone segments. In an exemplary embodiment, the apparatus further includes: one or more shear pins coupled between the upper tubular support member and the lower tubular support member. In an exemplary embodiment, the apparatus further includes: a stop member coupled to the upper tubular support member for limiting movement of the upper tubular support member relative to the lower tubular support member. In an exemplary embodiment, the apparatus further includes: a float shoe releasably coupled to the lower

tubular support member that defines a valveable passage, and an expandable tubular member coupled to the float shoe and supported by and movably coupled to the upper and lower expansion cone segments. In an exemplary embodiment, each upper expansion cone segment includes: an inner portion defining an arcuate cylindrical upper surface including a hinge groove for pivotally coupling the upper expansion cone segment to the upper tubular support member and arcuate cylindrical lower surfaces, an intermediate portion defining arcuate cylindrical and spherical upper surfaces and an arcuate conical lower surface, and an outer portion defining arcuate cylindrical upper and lower surfaces, and wherein each lower expansion cone segment includes: an inner portion defining an arcuate cylindrical upper surface including a hinge groove for pivotally coupling the lower expansion cone segment to the lower tubular support member and arcuate cylindrical lower surfaces, an intermediate portion defining arcuate cylindrical and spherical upper surfaces and an arcuate conical lower surface, and an outer portion defining arcuate cylindrical upper and lower surfaces. In an exemplary embodiment, each upper expansion cone segment is tapered in the longitudinal direction from the intermediate portion to the outer portion; and wherein each lower expansion cone segment is tapered in the longitudinal direction from the intermediate portion to the outer portion.

[0072] An apparatus for radially expanding and plastically deforming an expandable tubular member has also been described that includes a safety collar, a torque plate coupled to the safety collar including a plurality of circumferentially spaced apart meshing teeth at an end, an upper mandrel including a plurality of circumferentially spaced apart meshing teeth at one end for engaging the meshing teeth of the torque plate and an external flange at another end, a lower mandrel coupled to the external flange of the upper mandrel including an external flange including a plurality of circumferentially spaced apart meshing teeth, a stop nut coupled to an end of the lower mandrel, an upper retaining sleeve coupled to the lower mandrel including an internal flange, one or more cup seals coupled to the upper mandrel for sealing an interface between the upper mandrel and the expandable tubular member, an upper cam assembly coupled to the lower mandrel including: a tubular base including a plurality of circumferentially spaced apart meshing teeth for engaging the meshing teeth of the external flange of the lower mandrel, and a plurality of cam arms extending from the tubular base in a downward longitudinal direction, each cam arm defining an inclined surface, a plurality of upper expansion cone segments interleaved with the cam arms of the upper cam assembly and pivotally coupled to the internal flange of the upper retaining sleeve, a float shoe adapter including a plurality of circumferentially spaced apart meshing teeth at one end, an internal flange, and a torsional coupling at another end, a lower retaining sleeve coupled to an end of the float shoe adapter including an internal flange, a retaining sleeve received within the float shoe adapter, one or more shear pins for releasably coupling the retaining sleeve to the stop nut, a lower cam assembly coupled to the float shoe adapter including: a tubular base including a plurality of circumferentially spaced apart meshing teeth for engaging the meshing teeth of the float shoe adapter, and a plurality of cam arms extending from the tubular base in an upward longitudinal direction, each cam arm defining an inclined surface that mates

with the inclined surface of a corresponding one of the upper expansion cone segments, wherein the cam arms of the upper cam assembly are interleaved with and overlap the cam arms of the lower cam assembly, a plurality of lower expansion cone segments interleaved with cam arms of the lower cam assembly, each lower expansion cone segment pivotally coupled to the internal flange of the lower retaining sleeve and mating with the inclined surface of a corresponding one of the cam arms of the upper cam assembly, a float shoe releasably coupled to the torsional coupling of the float shoe adaptor, and an expandable tubular member coupled to the float shoe and supported by and movably coupled to the upper and lower expansion cone segments, wherein the lower expansion cone segments interleave and overlap the upper expansion cone segments, wherein the upper and lower expansion cone segments together define an arcuate spherical external surface for plastically deforming and radially expanding the expandable tubular member, wherein each upper expansion cone segment includes: an inner portion defining an arcuate cylindrical upper surface including a hinge groove for pivotally coupling the upper expansion cone segment to the upper tubular support member and arcuate cylindrical lower surfaces, an intermediate portion defining arcuate cylindrical and spherical upper surfaces and an arcuate conical lower surface, and an outer portion defining arcuate cylindrical upper and lower surfaces, wherein each lower expansion cone segment includes: an inner portion defining an arcuate cylindrical upper surface including a hinge groove for pivotally coupling the lower expansion cone segment to the lower tubular support member and arcuate cylindrical lower surfaces, an intermediate portion defining arcuate cylindrical and spherical upper surfaces and an arcuate conical lower surface, and an outer portion defining arcuate cylindrical upper and lower surfaces, wherein each upper expansion cone segment is tapered in the longitudinal direction from the intermediate portion to the outer portion, and wherein each lower expansion cone segment is tapered in the longitudinal direction from the intermediate portion to the outer portion.

[0073] A collapsible expansion cone assembly has also been described that includes an upper tubular support member including an internal flange, an upper cam assembly coupled to the upper tubular support member including: a tubular base coupled to the upper support member, and a plurality of cam arms extending from the tubular base in a downward longitudinal direction, each cam arm defining an inclined surface, a plurality of upper expansion cone segments interleaved with the cam arms of the upper cam assembly and pivotally coupled to the internal flange of the upper tubular support member, a lower tubular support member including an internal flange, one or more frangible couplings for releasably coupling the upper and lower tubular support members, a lower cam assembly coupled to the lower tubular support member including: a tubular base coupled to the lower tubular support member, and a plurality of cam arms extending from the tubular base in an upward longitudinal direction, each cam arm defining an inclined surface that mates with the inclined surface of a corresponding one of the upper expansion cone segments, wherein the cam arms of the upper cam assembly are interleaved with and overlap the cam arms of the lower cam assembly, and a plurality of lower expansion cone segments interleaved with cam arms of the lower cam assembly, each lower

expansion cone segment pivotally coupled to the internal flange of the lower tubular support member and mating with the inclined surface of a corresponding one of the cam arms of the upper cam assembly, wherein the lower expansion cone segments interleave and overlap the upper expansion cone segments, and wherein the upper and lower expansion cone segments together define an arcuate spherical external surface for plastically deforming and radially expanding the expandable tubular member. In an exemplary embodiment, each upper expansion cone segment includes: an inner portion defining an arcuate cylindrical upper surface including a hinge groove for pivotally coupling the upper expansion cone segment to the upper tubular support member and arcuate cylindrical lower surfaces, an intermediate portion defining arcuate cylindrical and spherical upper surfaces and an arcuate conical lower surface, and an outer portion defining arcuate cylindrical upper and lower surfaces, and wherein each lower expansion cone segment includes: an inner portion defining an arcuate cylindrical upper surface including a hinge groove for pivotally coupling the lower expansion cone segment to the lower tubular support member and arcuate cylindrical lower surfaces, an intermediate portion defining arcuate cylindrical and spherical upper surfaces and an arcuate conical lower surface, and an outer portion defining arcuate cylindrical upper and lower surfaces. In an exemplary embodiment, each upper expansion cone segment is tapered in the longitudinal direction from the intermediate portion to the outer portion, and wherein each lower expansion cone segment is tapered in the longitudinal direction from the intermediate portion to the outer portion.

[0074] A collapsible expansion cone assembly has also been described that includes an upper tubular support member including an internal flange, an upper cam assembly coupled to the upper tubular support member including: a tubular base coupled to the upper support member, and a plurality of cam arms extending from the tubular base in a downward longitudinal direction, each cam arm defining an inclined surface, a plurality of upper expansion cone segments interleaved with the cam arms of the upper cam assembly and pivotally coupled to the internal flange of the upper tubular support member, a lower tubular support member including an internal flange, one or more frangible couplings for releasably coupling the upper and lower tubular support members, a lower cam assembly coupled to the lower tubular support member including: a tubular base coupled to the lower tubular support member, and a plurality of cam arms extending from the tubular base in an upward longitudinal direction, each cam arm defining an inclined surface that mates with the inclined surface of a corresponding one of the upper expansion cone segments, wherein the cam arms of the upper cam assembly are interleaved with and overlap the cam arms of the lower cam assembly, and a plurality of lower expansion cone segments interleaved with cam arms of the lower cam assembly, each lower expansion cone segment pivotally coupled to the internal flange of the lower tubular support member and mating with the inclined surface of a corresponding one of the cam arms of the upper cam assembly, wherein the lower expansion cone segments interleave and overlap the upper expansion cone segments, wherein the upper and lower expansion cone segments together define an arcuate spherical external surface for plastically deforming and radially expanding the expandable tubular member,

wherein each upper expansion cone segment includes: an inner portion defining an arcuate cylindrical upper surface including a hinge groove for pivotally coupling the upper expansion cone segment to the upper tubular support member and arcuate cylindrical lower surfaces, an intermediate portion defining arcuate cylindrical and spherical upper surfaces and an arcuate conical lower surface, and an outer portion defining arcuate cylindrical upper and lower surfaces, wherein each lower expansion cone segment includes: an inner portion defining an arcuate cylindrical upper surface including a hinge groove for pivotally coupling the lower expansion cone segment to the lower tubular support member and arcuate cylindrical lower surfaces, an intermediate portion defining arcuate cylindrical and spherical upper surfaces and an arcuate conical lower surface, and an outer portion defining arcuate cylindrical upper and lower surfaces, wherein each upper expansion cone segment is tapered in the longitudinal direction from the intermediate portion to the outer portion, and wherein each lower expansion cone segment is tapered in the longitudinal direction from the intermediate portion to the outer portion.

[0075] An apparatus for radially expanding and plastically deforming an expandable tubular member has also been described that includes a tubular support member, a collapsible expansion cone coupled to the tubular support member, an expandable tubular member coupled to the collapsible expansion cone, means for displacing the collapsible expansion cone relative to the expandable tubular member, and means for collapsing the expansion cone. In an exemplary embodiment, the tubular support member includes an upper tubular support member including an internal flange and a lower tubular support member including an internal flange, wherein the expansion cone includes: an upper cam assembly coupled to the upper tubular support member including: a tubular base coupled to the upper support member, and a plurality of cam arms extending from the tubular base in a downward longitudinal direction, each cam arm defining an inclined surface, a plurality of upper expansion cone segments interleaved with the cam arms of the upper cam assembly and pivotally coupled to the internal flange of the upper tubular support member, a lower cam assembly coupled to the lower tubular support member including: a tubular base coupled to the lower tubular support member, and a plurality of cam arms extending from the tubular base in an upward longitudinal direction, each cam arm defining an inclined surface that mates with the inclined surface of a corresponding one of the upper expansion cone segments, wherein the cam arms of the upper cam assembly are interleaved with and overlap the cam arms of the lower cam assembly, and a plurality of lower expansion cone segments interleaved with cam arms of the lower cam assembly, each lower expansion cone segment pivotally coupled to the internal flange of the lower tubular support member and mating with the inclined surface of a corresponding one of the cam arms of the upper cam assembly; and wherein the apparatus further includes: means for releasably coupling the upper tubular support member to the lower tubular support member, and means for limiting movement of the upper tubular support member relative to the lower tubular support member. In an exemplary embodiment, the apparatus further includes: means for pivoting the upper expansion cone segments, and means for pivoting the lower expansion cone

segments. In an exemplary embodiment, the apparatus further includes: means for pulling the collapsible expansion cone through the expandable tubular member.

[0076] A collapsible expansion cone has also been described that includes an upper cam assembly including: a tubular base, and a plurality of cam arms extending from the tubular base in a downward longitudinal direction, each cam arm defining an inclined surface, a plurality of upper expansion cone segments interleaved with the cam arms of the upper cam assembly, a lower cam assembly including: a tubular base, and a plurality of cam arms extending from the tubular base in an upward longitudinal direction, each cam arm defining an inclined surface that mates with the inclined surface of a corresponding one of the upper expansion cone segments, wherein the cam arms of the upper cam assembly are interleaved with and overlap the cam arms of the lower cam assembly, a plurality of lower expansion cone segments interleaved with cam arms of the lower cam assembly, each lower expansion cone segment mating with the inclined surface of a corresponding one of the cam arms of the upper cam assembly, means for moving the upper cam assembly away from the lower expansion cone segments, and means for moving the lower cam assembly away from the upper expansion cone segments. In an exemplary embodiment, the upper and lower expansion cone segments together define an arcuate spherical external surface. In an exemplary embodiment, each upper expansion cone segment includes: an inner portion defining an arcuate upper surface and arcuate cylindrical lower surfaces, an intermediate portion defining arcuate cylindrical and spherical upper surfaces and an arcuate conical lower surface, and an outer portion defining arcuate cylindrical upper and lower surfaces, and wherein each lower expansion cone segment includes: an inner portion defining an arcuate cylindrical upper surface and arcuate cylindrical lower surfaces, an intermediate portion defining arcuate cylindrical and spherical upper surfaces and an arcuate conical lower surface, and an outer portion defining arcuate cylindrical upper and lower surfaces. In an exemplary embodiment, each upper expansion cone segment is tapered in the longitudinal direction from the intermediate portion to the outer portion, and each lower expansion cone segment is tapered in the longitudinal direction from the intermediate portion to the outer portion.

[0077] A method of radially expanding and plastically deforming an expandable tubular member has also been described that includes supporting the expandable tubular member using a tubular support member and a collapsible expansion cone, injecting a fluidic material into the tubular support member, sensing the operating pressure of the injected fluidic material within a first interior portion of the tubular support member, displacing the collapsible expansion cone relative to the expandable tubular member when the sensed operating pressure of the injected fluidic material exceeds a predetermined level within the first interior portion of the tubular support member, sensing the operating pressure of the injected fluidic material within a second interior portion of the tubular support member, and collapsing the collapsible expansion cone when the sensed operating pressure of the injected fluidic material exceeds a predetermined level within the second interior portion of the tubular support member. In an exemplary embodiment, the method further includes: pulling the collapsible

expansion cone through the expandable tubular member when the sensed operating pressure of the injected fluidic material exceeds a predetermined level within the first interior portion of the tubular support member. In an exemplary embodiment, pulling the collapsible expansion cone through the expandable tubular member includes: coupling one or more cup seals to the tubular support member above the collapsible expansion cone, pressuring the interior of the expandable tubular member below the cup seals, and pulling the collapsible expansion cone through the expandable tubular member using the cup seals. In an exemplary embodiment, the tubular support member includes an upper tubular support member and a lower tubular support member, and wherein collapsing the collapsible expansion cone includes displacing the upper tubular member relative to the lower tubular support member. In an exemplary embodiment, the collapsible expansion cone includes: an upper cam assembly including: a tubular base, and a plurality of cam arms extending from the tubular base in a downward longitudinal direction, each cam arm defining an inclined surface, a plurality of upper expansion cone segments interleaved with the cam arms of the upper cam assembly and pivotally coupled to the upper tubular support member, a lower cam assembly including: a tubular base, and a plurality of cam arms extending from the tubular base in an upward longitudinal direction, each cam arm defining an inclined surface that mates with the inclined surface of a corresponding one of the upper expansion cone segments, wherein the cam arms of the upper cam assembly are interleaved with and overlap the cam arms of the lower cam assembly, and a plurality of lower expansion cone segments interleaved with cam arms of the lower cam assembly, each lower expansion cone segment pivotally coupled to the lower tubular support member and mating with the inclined surface of a corresponding one of the cam arms of the upper cam assembly.

[0078] It is understood that variations may be made in the foregoing without departing from the scope of the invention. For example, the teachings of the present illustrative embodiments may be used to provide a wellbore casing, a pipeline, or a structural support. Furthermore, the elements and teachings of the various illustrative embodiments may be combined in whole or in part in some or all of the illustrative embodiments. In addition, the expansion surfaces of the expansion cone segments may include any form of inclined surface or combination of inclined surface such as, for example, conical, spherical, elliptical, and/or parabolic.

[0079] Although illustrative embodiments of the invention have been shown and described, a wide range of modification, changes and substitution is contemplated in the foregoing disclosure. In some instances, some features of the present invention may be employed without a corresponding use of the other features. Accordingly, it is appropriate that the appended claims be construed broadly and in a manner consistent with the scope of the invention.

## Claims

What is claimed is:

1. An apparatus for radially expanding and plastically deforming an expandable tubular member, comprising:
  - an upper tubular support member defining a first passage;
  - one or more cup seals coupled to the exterior surface of the upper tubular support member for sealing an interface between the upper tubular support member and the expandable tubular member;
  - an upper cam assembly coupled to the upper tubular support member comprising:
    - a tubular base coupled to the upper tubular support member; and
    - a plurality of cam arms extending from the tubular base in a downward longitudinal direction, each cam arm defining an inclined surface;
  - a plurality of upper expansion cone segments interleaved with the cam arms of the upper cam assembly and pivotally coupled to the tubular support member;
  - a lower tubular support member defining a second passage fluidically coupled to the first passage releasably coupled to the upper tubular support member;
  - a lower cam assembly coupled to the lower tubular support member comprising:
    - a tubular base coupled to the lower tubular support member; and
    - a plurality of cam arms extending from the tubular base in an upward longitudinal direction, each cam arm defining an inclined surface that mates with the inclined surface of a corresponding one of the upper expansion cone segments;
  - wherein the cam arms of the upper cam assembly are interleaved with and overlap the cam arms of the lower cam assembly; and
  - a plurality of lower expansion cone segments interleaved with cam arms of the lower cam assembly, each lower expansion cone segment pivotally coupled to the lower tubular support member and mating with the inclined surface of a corresponding one of the cam arms of the upper cam assembly;
    - wherein the lower expansion cone segments interleave and overlap the upper expansion cone segments; and
    - wherein the upper and lower expansion cone segments together define an arcuate spherical external surface for plastically deforming and radially expanding the expandable tubular member.
2. The apparatus of claim 1, wherein the upper tubular support member comprises:
  - a safety collar;



- a torque plate coupled to the safety collar comprising a plurality of circumferentially spaced apart meshing teeth at an end;  
an upper mandrel comprising a plurality of circumferentially spaced apart meshing teeth at one end for engaging the meshing teeth of the torque plate and an external flange at another end; and  
a lower mandrel coupled to the external flange of the upper mandrel comprising an external flange comprising a plurality of circumferentially spaced apart meshing teeth.
3. The apparatus of claim 2, wherein the tubular base of the upper cam assembly comprises a plurality of circumferentially spaced apart meshing teeth for engaging the meshing teeth of the external flange of the lower mandrel.
  4. The apparatus of claim 2, further comprising:  
a stop nut coupled to an end of the lower mandrel for limiting the movement of the lower tubular member relative to the lower mandrel.
  5. The apparatus of claim 2, further comprising:  
locking dogs coupled to the lower mandrel.
  6. The apparatus of claim 1, wherein the lower tubular support member comprises:  
a float shoe adapter comprising a plurality of circumferentially spaced apart meshing teeth at one end, an internal flange, and a torsional coupling at another end;  
a lower retaining sleeve coupled to an end of the float shoe adapter comprising an internal flange for pivotally engaging the lower expansion cone segments; and  
a retaining sleeve received within the float shoe adapter releasably coupled to the upper tubular support member.
  7. The apparatus of claim 6, wherein an end of the retaining sleeve abuts an end of the tubular base of the lower cam assembly.
  8. The apparatus of claim 6, wherein the tubular base of the lower cam assembly comprises a plurality of circumferentially spaced apart meshing teeth for engaging the meshing teeth of the float shoe adaptor.
  9. The apparatus of claim 6, further comprising:  
a float shoe releasably coupled to the torsional coupling of the float shoe adaptor; and  
an expandable tubular member coupled to the float shoe and supported by and movably coupled to the upper and lower expansion cone segments.
  10. The apparatus of claim 1, further comprising:  
one or more shear pins coupled between the upper tubular support member and the lower tubular support member.
  11. The apparatus of claim 1, further comprising:  
a stop member coupled to the upper tubular support member for limiting movement of the upper tubular support member relative to the lower tubular support member.

12. The apparatus of claim 1, further comprising:  
a float shoe releasably coupled to the lower tubular support member that defines a valveable passage; and  
an expandable tubular member coupled to the float shoe and supported by and movably coupled to the upper and lower expansion cone segments.
13. The apparatus of claim 1, wherein each upper expansion cone segment comprises:  
an inner portion defining an arcuate cylindrical upper surface including a hinge groove for pivotally coupling the upper expansion cone segment to the upper tubular support member and arcuate cylindrical lower surfaces;  
an intermediate portion defining arcuate cylindrical and spherical upper surfaces and an arcuate conical lower surface; and  
an outer portion defining arcuate cylindrical upper and lower surfaces; and  
wherein each lower expansion cone segment comprises:  
an inner portion defining an arcuate cylindrical upper surface including a hinge groove for pivotally coupling the lower expansion cone segment to the lower tubular support member and arcuate cylindrical lower surfaces;  
an intermediate portion defining arcuate cylindrical and spherical upper surfaces and an arcuate conical lower surface; and  
an outer portion defining arcuate cylindrical upper and lower surfaces.
14. The apparatus of claim 13, wherein each upper expansion cone segment is tapered in the longitudinal direction from the intermediate portion to the outer portion; and wherein each lower expansion cone segment is tapered in the longitudinal direction from the intermediate portion to the outer portion.
15. An apparatus for radially expanding and plastically deforming an expandable tubular member, comprising:  
a safety collar;  
a torque plate coupled to the safety collar comprising a plurality of circumferentially spaced apart meshing teeth at an end;  
an upper mandrel comprising a plurality of circumferentially spaced apart meshing teeth at one end for engaging the meshing teeth of the torque plate and an external flange at another end;  
a lower mandrel coupled to the external flange of the upper mandrel comprising an external flange comprising a plurality of circumferentially spaced apart meshing teeth;  
a stop nut coupled to an end of the lower mandrel;  
an upper retaining sleeve coupled to the lower mandrel comprising an internal flange;  
one or more cup seals coupled to the upper mandrel for sealing an interface between the upper mandrel and the expandable tubular member;

- an upper cam assembly coupled to the lower mandrel comprising:
- a tubular base comprising a plurality of circumferentially spaced apart meshing teeth for engaging the meshing teeth of the external flange of the lower mandrel; and
  - a plurality of cam arms extending from the tubular base in a downward longitudinal direction, each cam arm defining an inclined surface;
- a plurality of upper expansion cone segments interleaved with the cam arms of the upper cam assembly and pivotally coupled to the internal flange of the upper retaining sleeve;
- a float shoe adapter comprising a plurality of circumferentially spaced apart meshing teeth at one end, an internal flange, and a torsional coupling at another end;
- a lower retaining sleeve coupled to an end of the float shoe adapter comprising an internal flange;
- a retaining sleeve received within the float shoe adapter;
- one or more shear pins for releasably coupling the retaining sleeve to the stop nut;
- a lower cam assembly coupled to the float shoe adapter comprising:
- a tubular base comprising a plurality of circumferentially spaced apart meshing teeth for engaging the meshing teeth of the float shoe adapter; and
  - a plurality of cam arms extending from the tubular base in an upward longitudinal direction, each cam arm defining an inclined surface that mates with the inclined surface of a corresponding one of the upper expansion cone segments;
- wherein the cam arms of the upper cam assembly are interleaved with and overlap the cam arms of the lower cam assembly;
- a plurality of lower expansion cone segments interleaved with cam arms of the lower cam assembly, each lower expansion cone segment pivotally coupled to the internal flange of the lower retaining sleeve and mating with the inclined surface of a corresponding one of the cam arms of the upper cam assembly;
- a float shoe releasably coupled to the torsional coupling of the float shoe adaptor; and
- an expandable tubular member coupled to the float shoe and supported by and movably coupled to the upper and lower expansion cone segments;
- wherein the lower expansion cone segments interleave and overlap the upper expansion cone segments;
- wherein the upper and lower expansion cone segments together define an arcuate spherical external surface for plastically deforming and radially expanding the expandable tubular member;
- wherein each upper expansion cone segment comprises:
- an inner portion defining an arcuate cylindrical upper surface including a hinge groove for pivotally coupling the upper expansion cone segment to the upper tubular support member and arcuate cylindrical lower surface;

an intermediate portion defining arcuate cylindrical and spherical upper surfaces and an arcuate conical lower surface; and

an outer portion defining arcuate cylindrical upper and lower surfaces;

wherein each lower expansion cone segment comprises:

an inner portion defining an arcuate cylindrical upper surface including a hinge groove for pivotally coupling the lower expansion cone segment to the lower tubular support member and arcuate cylindrical lower surfaces;

an intermediate portion defining arcuate cylindrical and spherical upper surfaces and an arcuate conical lower surface; and

an outer portion defining arcuate cylindrical upper and lower surfaces;

wherein each upper expansion cone segment is tapered in the longitudinal direction from the intermediate portion to the outer portion; and

wherein each lower expansion cone segment is tapered in the longitudinal direction from the intermediate portion to the outer portion.

16. A collapsible expansion cone assembly comprising:

a upper tubular support member comprising an internal flange;

an upper cam assembly coupled to the upper tubular support member comprising:

a tubular base coupled to the upper support member; and

a plurality of cam arms extending from the tubular base in a downward longitudinal direction, each cam arm defining an inclined surface;

a plurality of upper expansion cone segments interleaved with the cam arms of the upper cam assembly and pivotally coupled to the internal flange of the upper tubular support member;

a lower tubular support member comprising an internal flange;

one or more frangible couplings for releasably coupling the upper and lower tubular support members;

a lower cam assembly coupled to the lower tubular support member comprising:

a tubular base coupled to the lower tubular support member; and

a plurality of cam arms extending from the tubular base in an upward longitudinal direction, each cam arm defining an inclined surface that mates with the inclined surface of a corresponding one of the upper expansion cone segments;

wherein the cam arms of the upper cam assembly are interleaved with and overlap the cam arms of the lower cam assembly; and

a plurality of lower expansion cone segments interleaved with cam arms of the lower cam assembly, each lower expansion cone segment pivotally coupled to the internal flange of the lower tubular support member and mating with the inclined surface of a corresponding one of the cam arms of the upper cam assembly;

- wherein the lower expansion cone segments interleave and overlap the upper expansion cone segments; and
- wherein the upper and lower expansion cone segments together define an arcuate spherical external surface for plastically deforming and radially expanding the expandable tubular member.
17. The assembly of claim 16, wherein each upper expansion cone segment comprises:
- an inner portion defining an arcuate cylindrical upper surface including a hinge groove for pivotally coupling the upper expansion cone segment to the upper tubular support member and arcuate cylindrical lower surfaces;
  - an intermediate portion defining arcuate cylindrical and spherical upper surfaces and an arcuate conical lower surface; and
  - an outer portion defining arcuate cylindrical upper and lower surfaces; and
- wherein each lower expansion cone segment comprises:
- an inner portion defining an arcuate cylindrical upper surface including a hinge groove for pivotally coupling the lower expansion cone segment to the lower tubular support member and arcuate cylindrical lower surfaces;
  - an intermediate portion defining arcuate cylindrical and spherical upper surfaces and an arcuate conical lower surface; and
  - an outer portion defining arcuate cylindrical upper and lower surfaces.
18. The assembly of claim 16, wherein each upper expansion cone segment is tapered in the longitudinal direction from the intermediate portion to the outer portion; and wherein each lower expansion cone segment is tapered in the longitudinal direction from the intermediate portion to the outer portion.
19. A collapsible expansion cone assembly, comprising:
- an upper tubular support member comprising an internal flange;
  - an upper cam assembly coupled to the upper tubular support member comprising:
    - a tubular base coupled to the upper support member; and
    - a plurality of cam arms extending from the tubular base in a downward longitudinal direction, each cam arm defining an inclined surface;
  - a plurality of upper expansion cone segments interleaved with the cam arms of the upper cam assembly and pivotally coupled to the internal flange of the upper tubular support member;
  - a lower tubular support member comprising an internal flange;
  - one or more frangible couplings for releasably coupling the upper and lower tubular support members;
  - a lower cam assembly coupled to the lower tubular support member comprising:
    - a tubular base coupled to the lower tubular support member; and

a plurality of cam arms extending from the tubular base in an upward longitudinal direction, each cam arm defining an inclined surface that mates with the inclined surface of a corresponding one of the upper expansion cone segments; wherein the cam arms of the upper cam assembly are interleaved with and overlap the cam arms of the lower cam assembly; and

a plurality of lower expansion cone segments interleaved with cam arms of the lower cam assembly, each lower expansion cone segment pivotally coupled to the internal flange of the lower tubular support member and mating with the inclined surface of a corresponding one of the cam arms of the upper cam assembly;

wherein the lower expansion cone segments interleave and overlap the upper expansion cone segments;

wherein the upper and lower expansion cone segments together define an arcuate spherical external surface for plastically deforming and radially expanding the expandable tubular member;

wherein each upper expansion cone segment comprises:

an inner portion defining an arcuate cylindrical upper surface including a hinge groove for pivotally coupling the upper expansion cone segment to the upper tubular support member and arcuate cylindrical lower surfaces;

an intermediate portion defining arcuate cylindrical and spherical upper surfaces and an arcuate conical lower surface; and

an outer portion defining arcuate cylindrical upper and lower surfaces;

wherein each lower expansion cone segment comprises:

an inner portion defining an arcuate cylindrical upper surface including a hinge groove for pivotally coupling the lower expansion cone segment to the lower tubular support member and arcuate cylindrical lower surfaces;

an intermediate portion defining arcuate cylindrical and spherical upper surfaces and an arcuate conical lower surface; and

an outer portion defining arcuate cylindrical upper and lower surfaces;

wherein each upper expansion cone segment is tapered in the longitudinal direction from the intermediate portion to the outer portion; and

wherein each lower expansion cone segment is tapered in the longitudinal direction from the intermediate portion to the outer portion.

20. An apparatus for radially expanding and plastically deforming an expandable tubular member, comprising:

a tubular support member;

a collapsible expansion cone coupled to the tubular support member;

an expandable tubular member coupled to the collapsible expansion cone;

means for displacing the collapsible expansion cone relative to the expandable tubular member;  
and

means for collapsing the expansion cone.

21. The apparatus of claim 20, wherein the tubular support member comprises an upper tubular support member comprising an internal flange and a lower tubular support member comprising an internal flange; wherein the expansion cone comprises:

an upper cam assembly coupled to the upper tubular support member comprising:

a tubular base coupled to the upper support member; and

a plurality of cam arms extending from the tubular base in a downward longitudinal direction, each cam arm defining an inclined surface;

a plurality of upper expansion cone segments interleaved with the cam arms of the upper cam assembly and pivotally coupled to the internal flange of the upper tubular support member;

a lower cam assembly coupled to the lower tubular support member comprising:

a tubular base coupled to the lower tubular support member; and

a plurality of cam arms extending from the tubular base in an upward longitudinal direction, each cam arm defining an inclined surface that mates with the inclined surface of a corresponding one of the upper expansion cone segments;

wherein the cam arms of the upper cam assembly are interleaved with and overlap the cam arms of the lower cam assembly; and

a plurality of lower expansion cone segments interleaved with cam arms of the lower cam assembly, each lower expansion cone segment pivotally coupled to the internal flange of the lower tubular support member and mating with the inclined surface of a corresponding one of the cam arms of the upper cam assembly; and wherein the apparatus further comprises:

means for releasably coupling the upper tubular support member to the lower tubular support member; and

means for limiting movement of the upper tubular support member relative to the lower tubular support member.

22. The apparatus of claim 20, further comprising:

means for pivoting the upper expansion cone segments; and

means for pivoting the lower expansion cone segments.

23. The apparatus of claim 20, further comprising:

means for pulling the collapsible expansion cone through the expandable tubular member.

24. A collapsible expansion cone, comprising:

an upper cam assembly comprising:

a tubular base; and

- a plurality of cam arms extending from the tubular base in a downward longitudinal direction, each cam arm defining an inclined surface;
- a plurality of upper expansion cone segments interleaved with the cam arms of the upper cam assembly;
- a lower cam assembly comprising:
- a tubular base; and
  - a plurality of cam arms extending from the tubular base in an upward longitudinal direction, each cam arm defining an inclined surface that mates with the inclined surface of a corresponding one of the upper expansion cone segments; wherein the cam arms of the upper cam assembly are interleaved with and overlap the cam arms of the lower cam assembly;
- a plurality of lower expansion cone segments interleaved with cam arms of the lower cam assembly, each lower expansion cone segment mating with the inclined surface of a corresponding one of the cam arms of the upper cam assembly;
- means for moving the upper cam assembly away from the lower expansion cone segments; and
- means for moving the lower cam assembly away from the upper expansion cone segments.
25. The apparatus of claim 24, wherein the upper and lower expansion cone segments together define an arcuate spherical external surface.
26. The apparatus of claim 24, wherein each upper expansion cone segment comprises:
- an inner portion defining an arcuate cylindrical upper surface and arcuate cylindrical lower surfaces;
  - an intermediate portion defining arcuate cylindrical and spherical upper surfaces and an arcuate conical lower surface; and
  - an outer portion defining arcuate cylindrical upper and lower surfaces; and
- wherein each lower expansion cone segment comprises:
- an inner portion defining an arcuate cylindrical upper surface and arcuate cylindrical lower surfaces;
  - an intermediate portion defining arcuate cylindrical and spherical upper surfaces and an arcuate conical lower surface; and
  - an outer portion defining arcuate cylindrical upper and lower surfaces.
27. The apparatus of claim 24, wherein each upper expansion cone segment is tapered in the longitudinal direction from the intermediate portion to the outer portion; and
- wherein each lower expansion cone segment is tapered in the longitudinal direction from the intermediate portion to the outer portion.
28. A method of radially expanding and plastically deforming an expandable tubular member, comprising:



- supporting the expandable tubular member using a tubular support member and a collapsible expansion cone;  
injecting a fluidic material into the tubular support member;  
sensing the operating pressure of the injected fluidic material within a first interior portion of the tubular support member;  
displacing the collapsible expansion cone relative to the expandable tubular member when the sensed operating pressure of the injected fluidic material exceeds a predetermined level within the first interior portion of the tubular support member;  
sensing the operating pressure of the injected fluidic material within a second interior portion of the tubular support member; and  
collapsing the collapsible expansion cone when the sensed operating pressure of the injected fluidic material exceeds a predetermined level within the second interior portion of the tubular support member.
29. The method of claim 28, further comprising:  
pulling the collapsible expansion cone through the expandable tubular member when the sensed operating pressure of the injected fluidic material exceeds a predetermined level within the first interior portion of the tubular support member.
30. The method of claim 29, wherein pulling the collapsible expansion cone through the expandable tubular member comprises:  
coupling one or more cup seals to the tubular support member above the collapsible expansion cone;  
pressuring the interior of the expandable tubular member below the cup seals; and  
pulling the collapsible expansion cone through the expandable tubular member using the cup seals.
31. The method of claim 28, wherein the tubular support member comprises an upper tubular support member and a lower tubular support member; and wherein collapsing the collapsible expansion cone comprises displacing the upper tubular member relative to the lower tubular support member.
32. The method of claim 31, wherein the collapsible expansion cone comprises:  
an upper cam assembly comprising:  
a tubular base; and  
a plurality of cam arms extending from the tubular base in a downward longitudinal direction, each cam arm defining an inclined surface;  
a plurality of upper expansion cone segments interleaved with the cam arms of the upper cam assembly and pivotally coupled to the upper tubular support member;  
a lower cam assembly comprising:  
a tubular base; and

a plurality of cam arms extending from the tubular base in an upward longitudinal direction,  
each cam arm defining an inclined surface that mates with the inclined surface of a  
corresponding one of the upper expansion cone segments;

wherein the cam arms of the upper cam assembly are interleaved with and overlap the cam  
arms of the lower cam assembly; and

a plurality of lower expansion cone segments interleaved with cam arms of the lower cam assembly,  
each lower expansion cone segment pivotally coupled to the lower tubular support member and  
mating with the inclined surface of a corresponding one of the cam arms of the upper cam  
assembly.

10  
↓

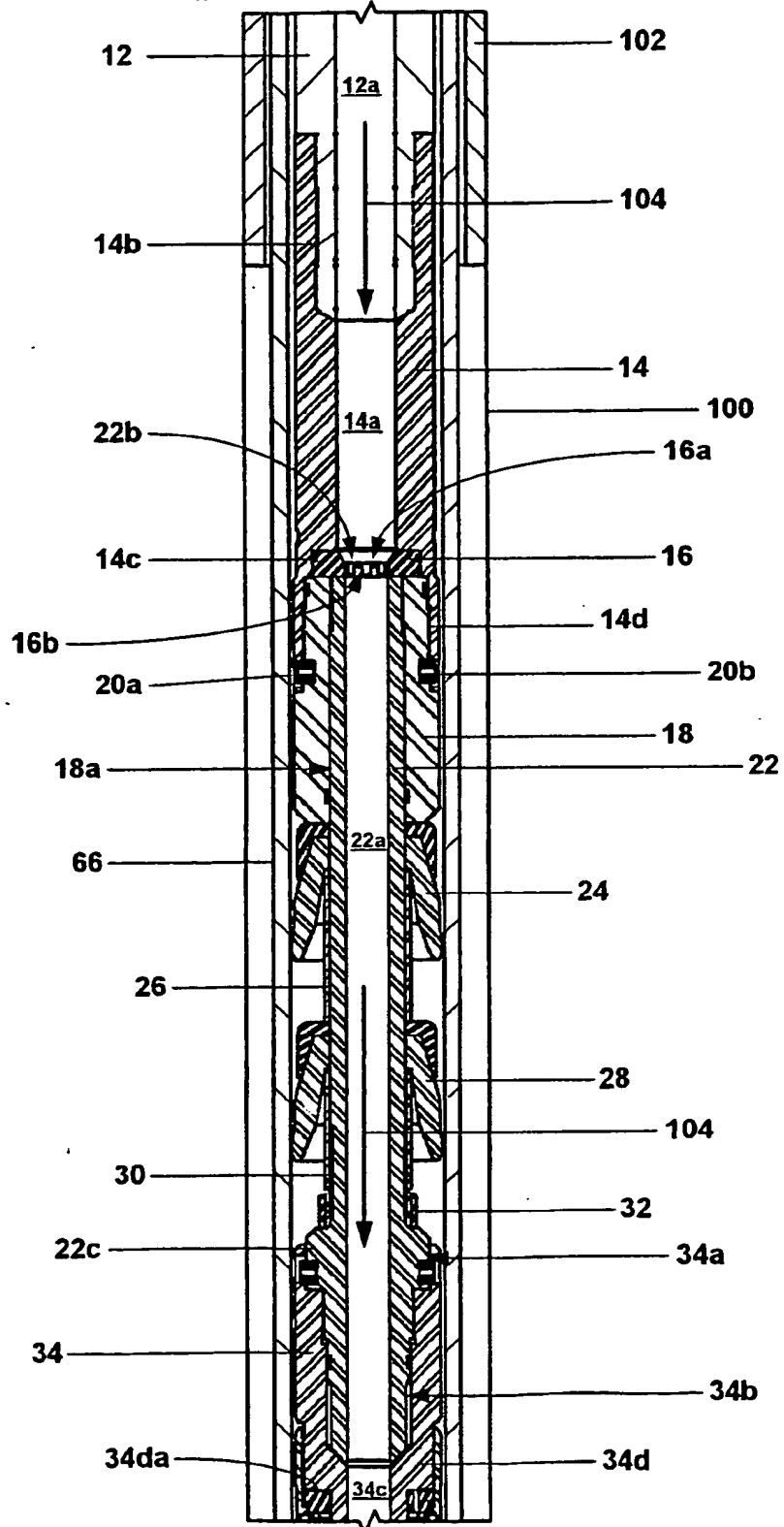
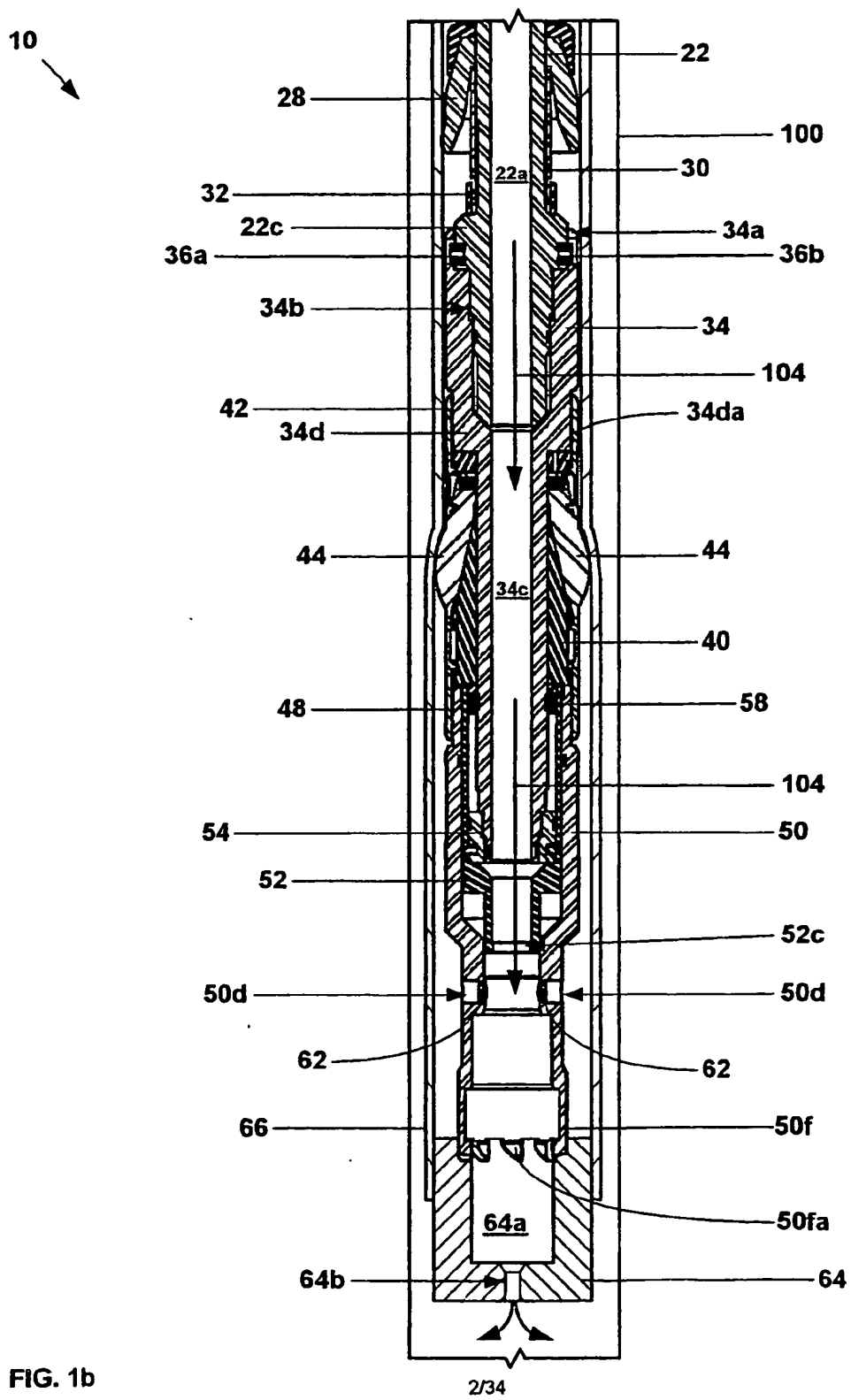

FIG. 1a





10

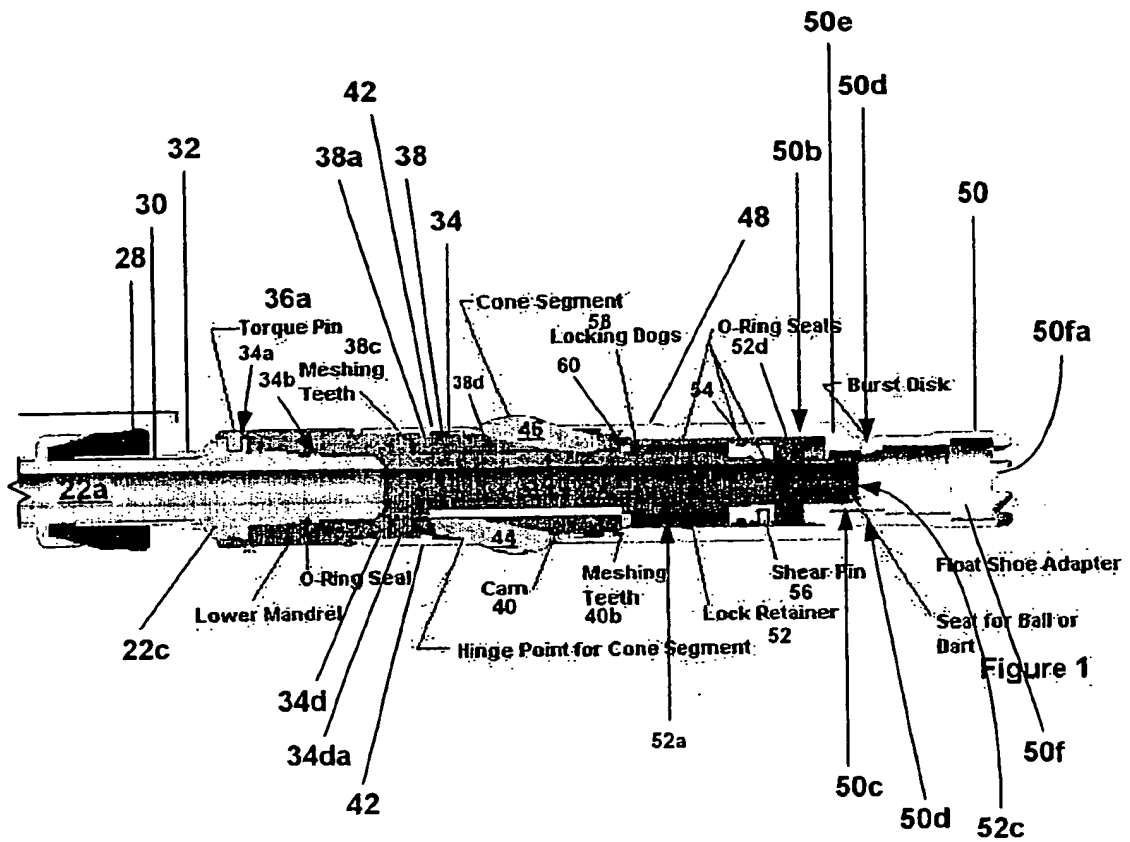

FIG. 2b

10  
↙

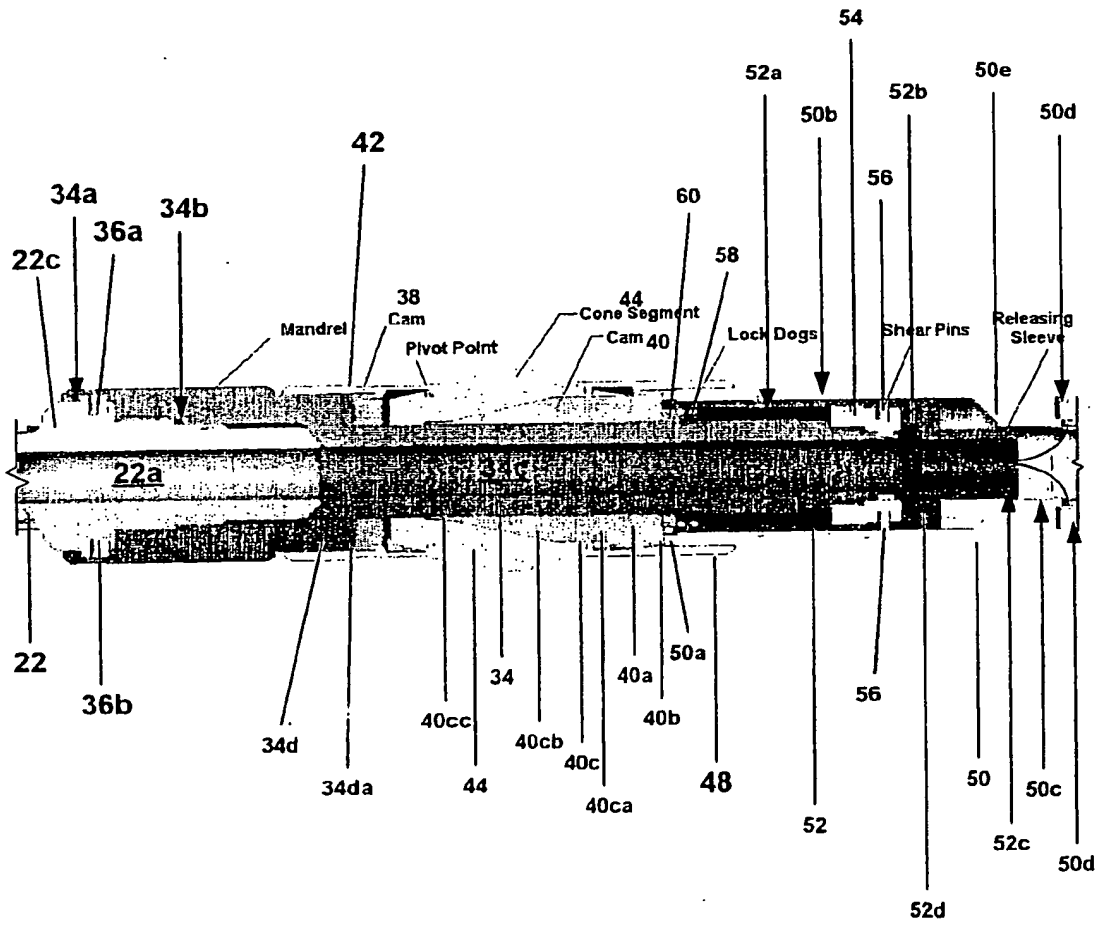

FIG. 3

10

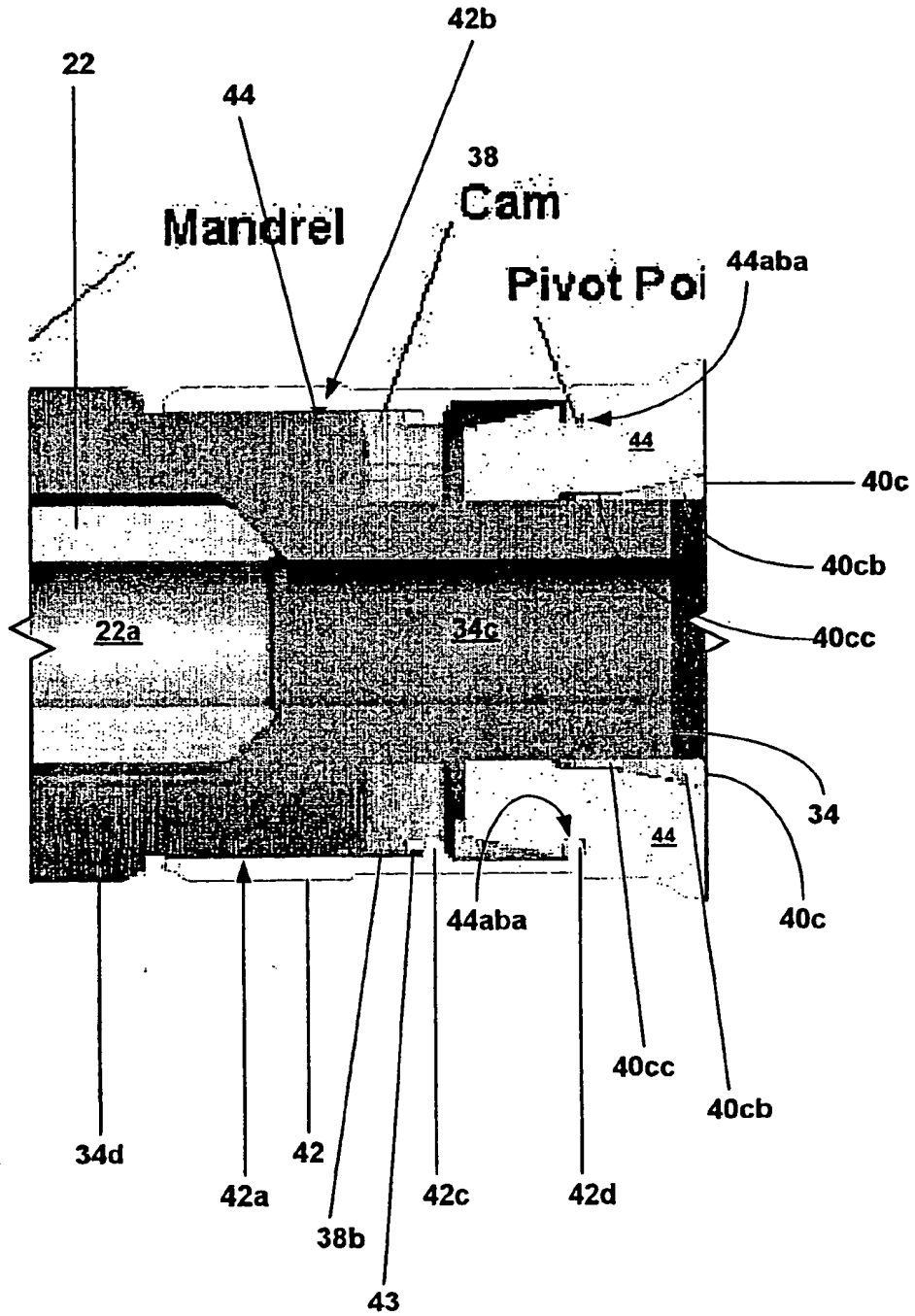

FIG. 3a



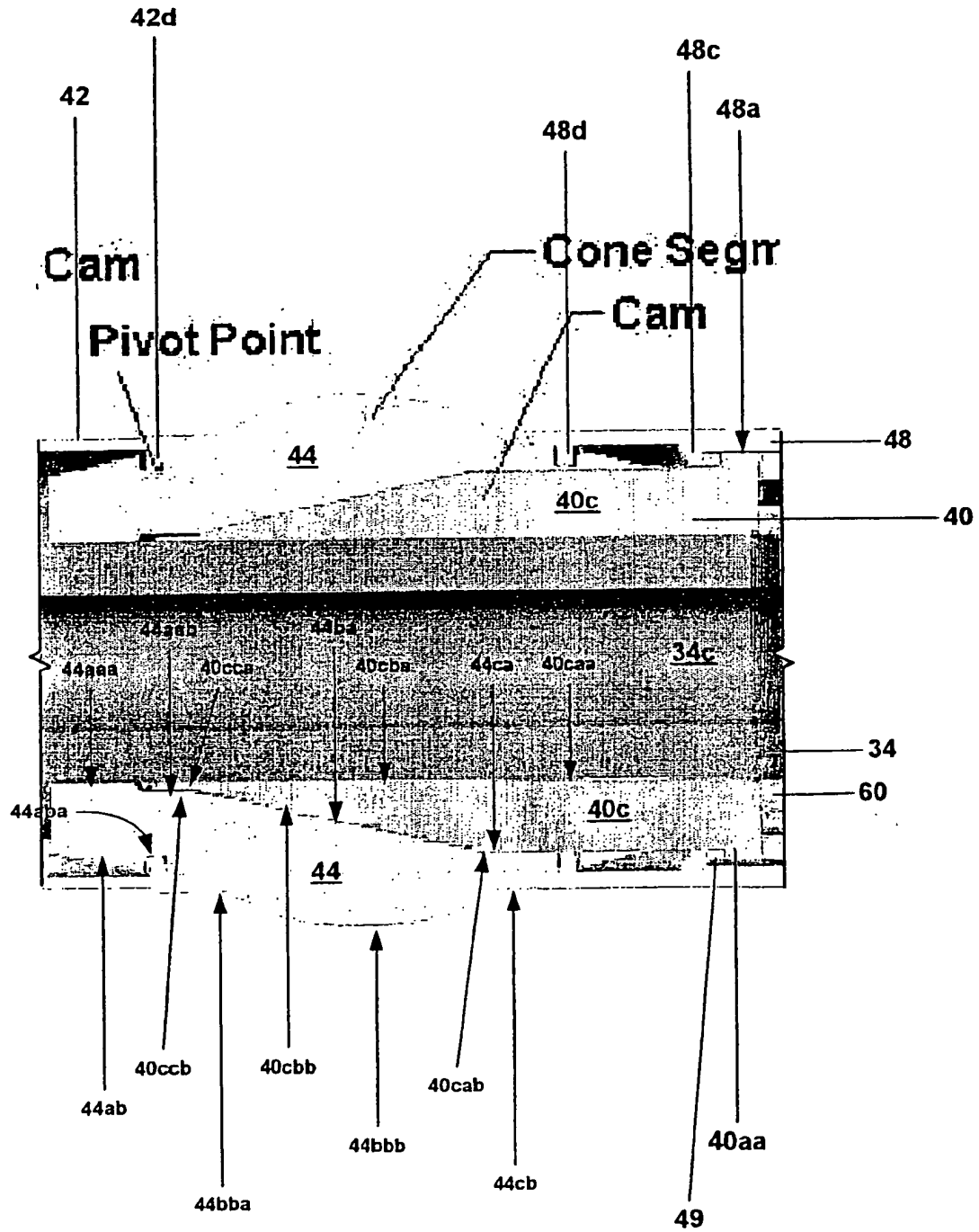

FIG. 3b

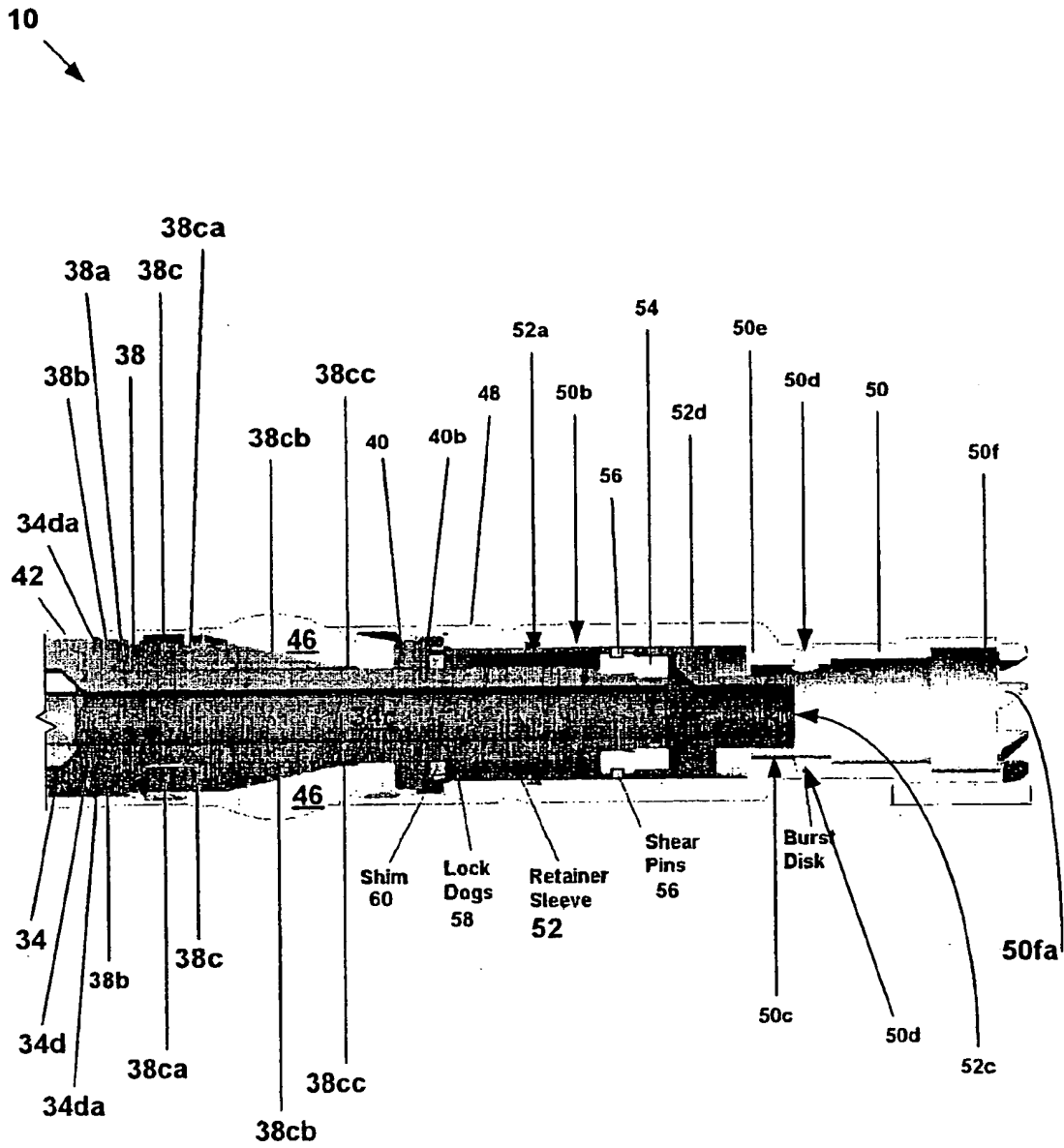

FIG. 4

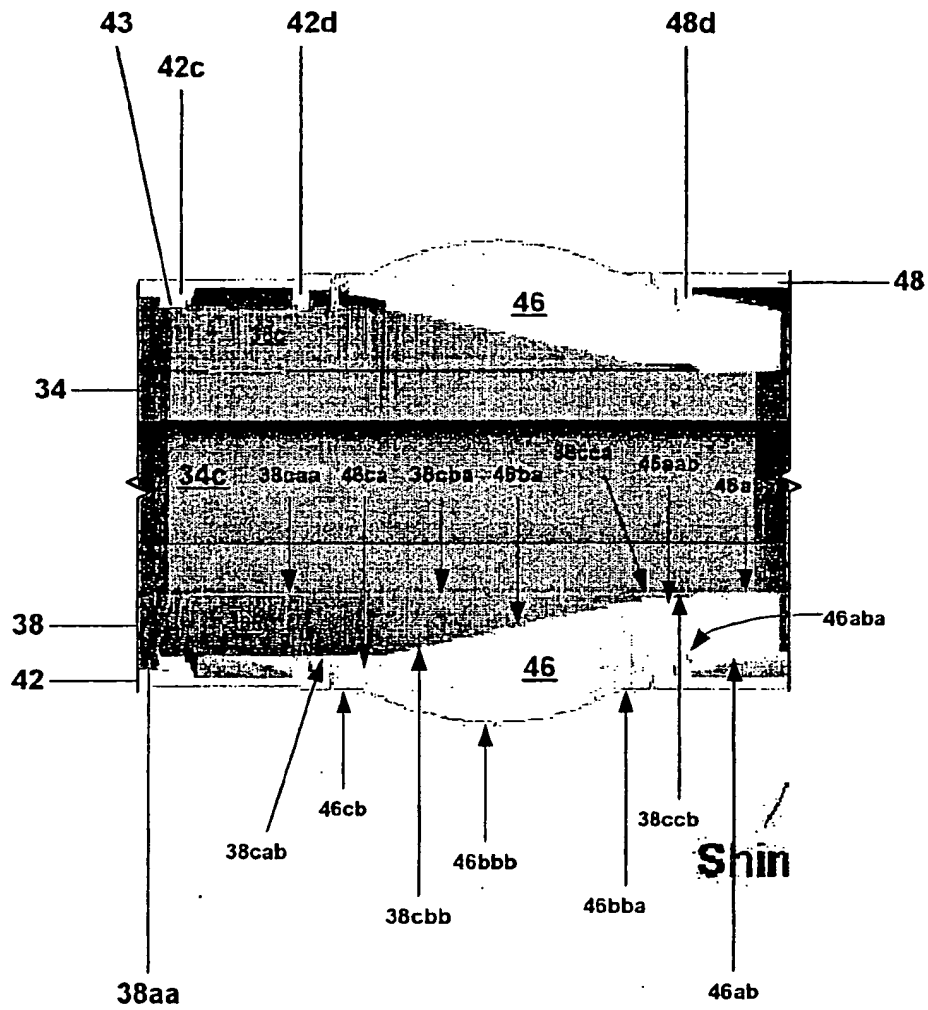

FIG. 4a

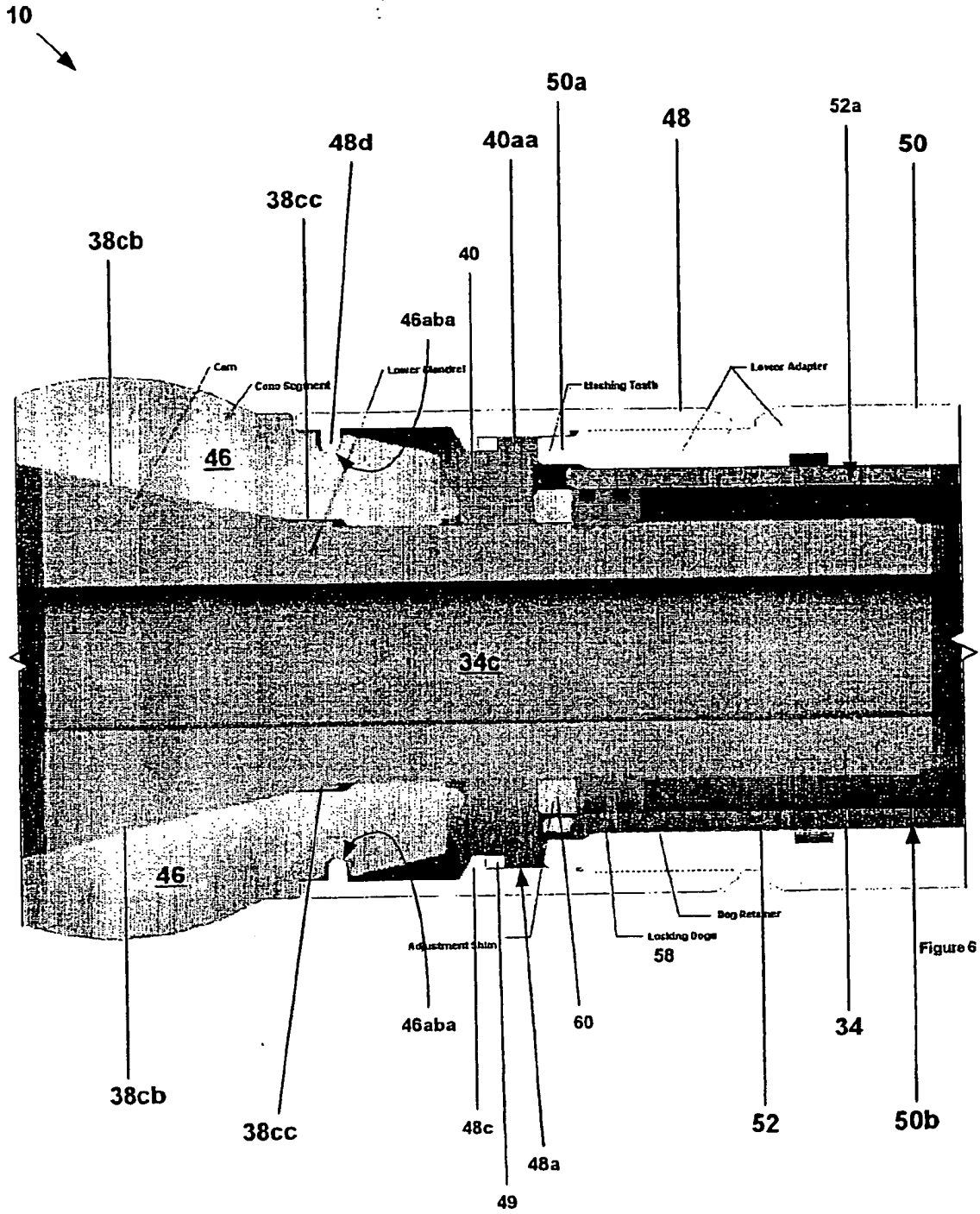

FIG. 5

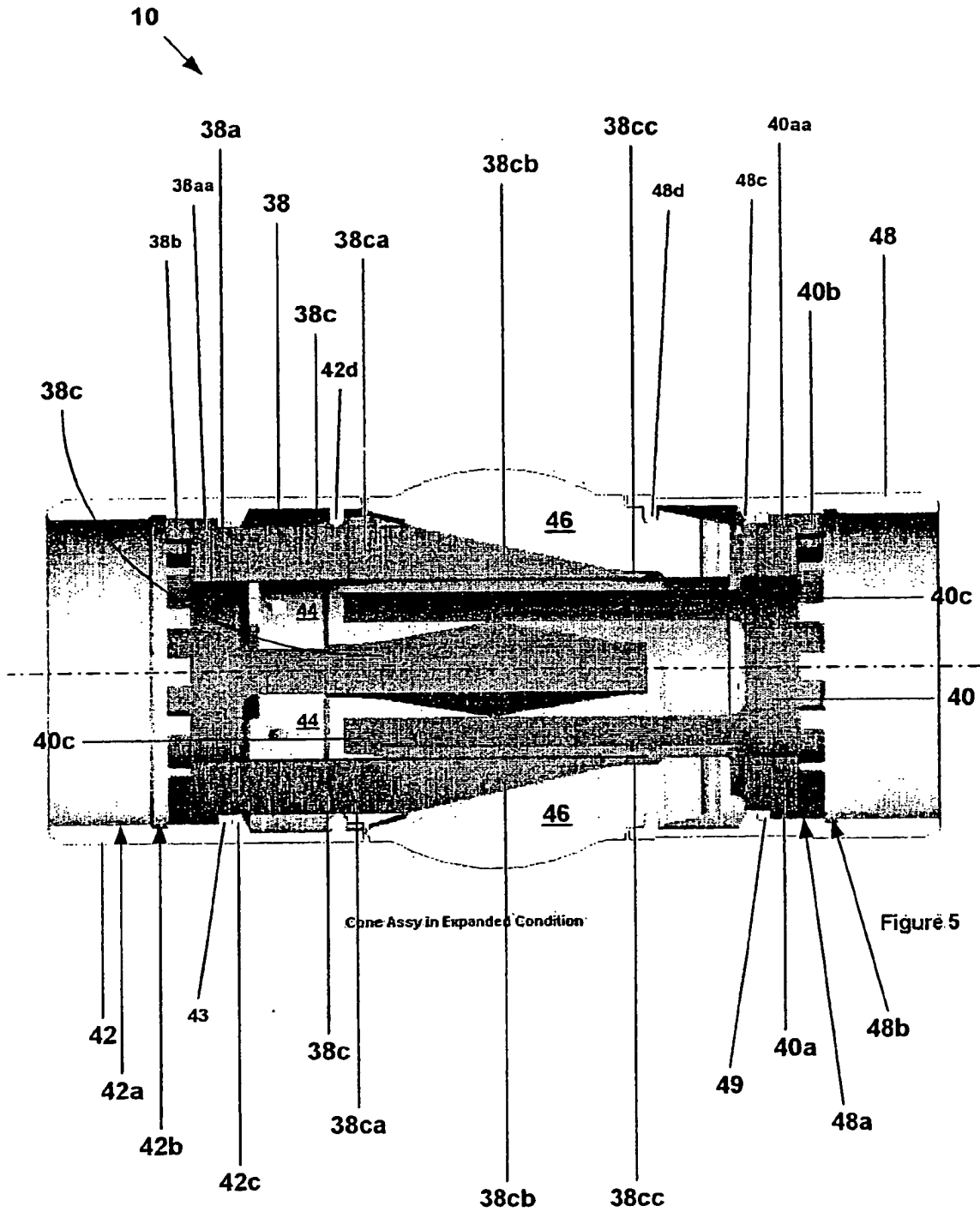

FIG. 6

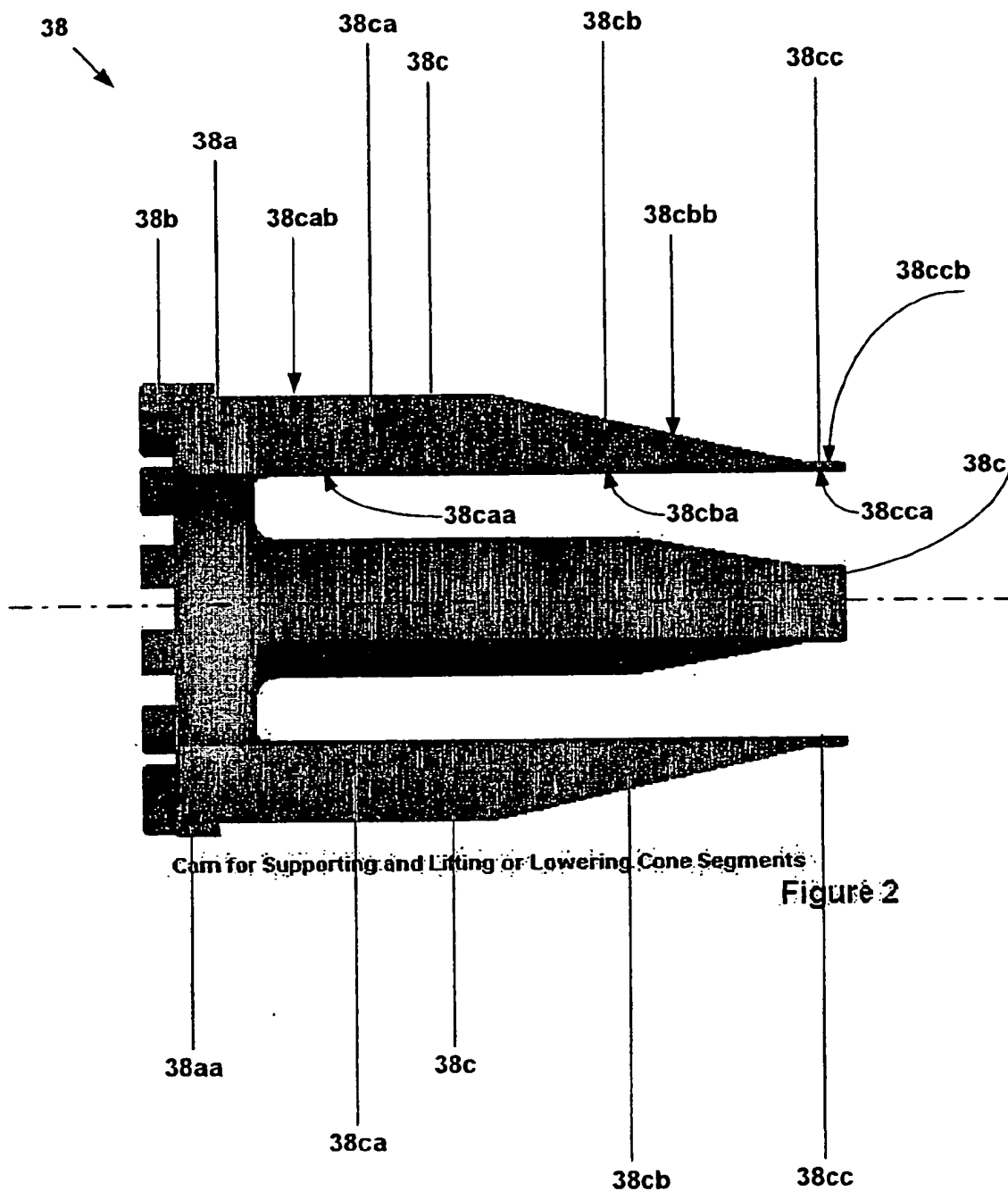

FIG. 7a

38 ↘

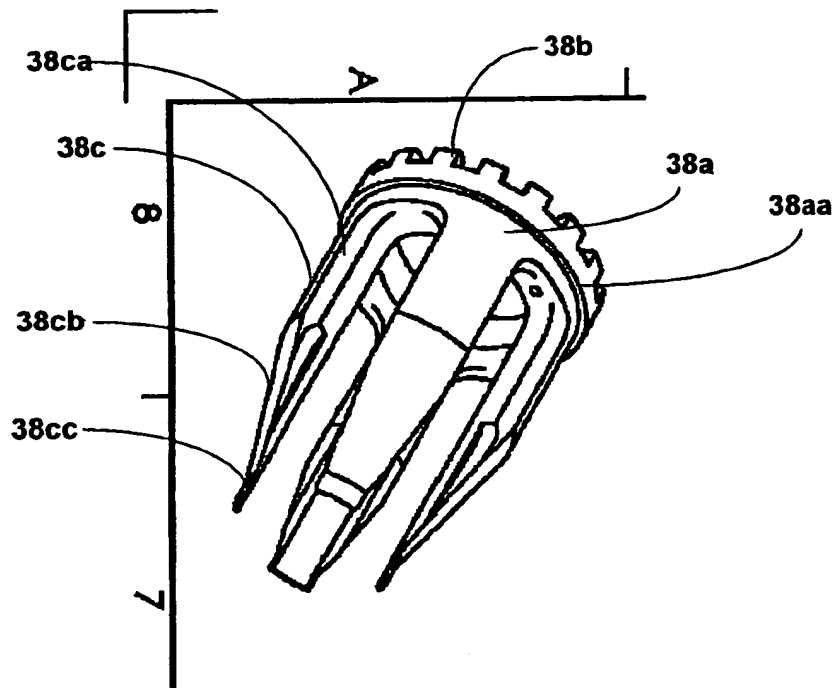

FIG. 7b.

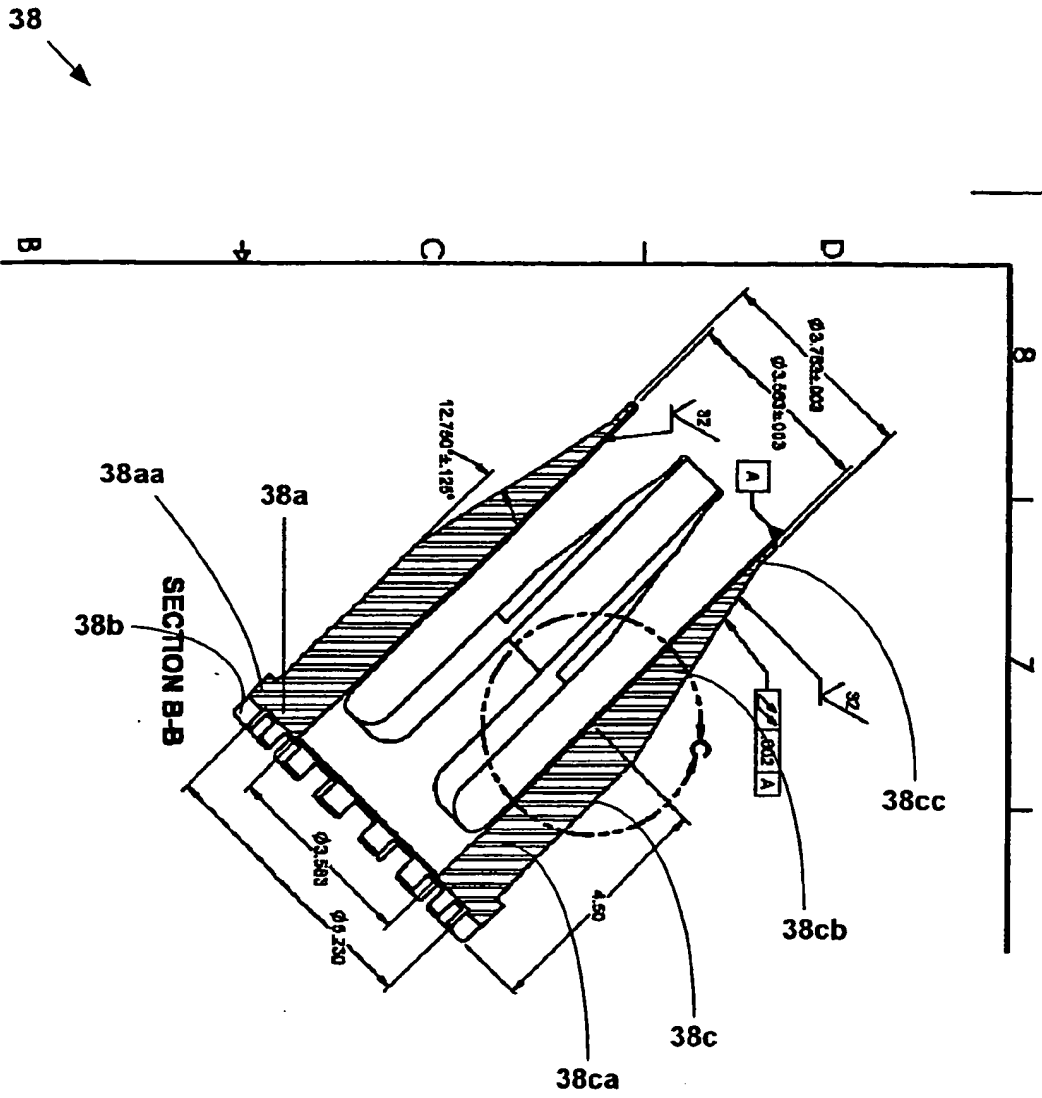

FIG. 7c



38  
↙

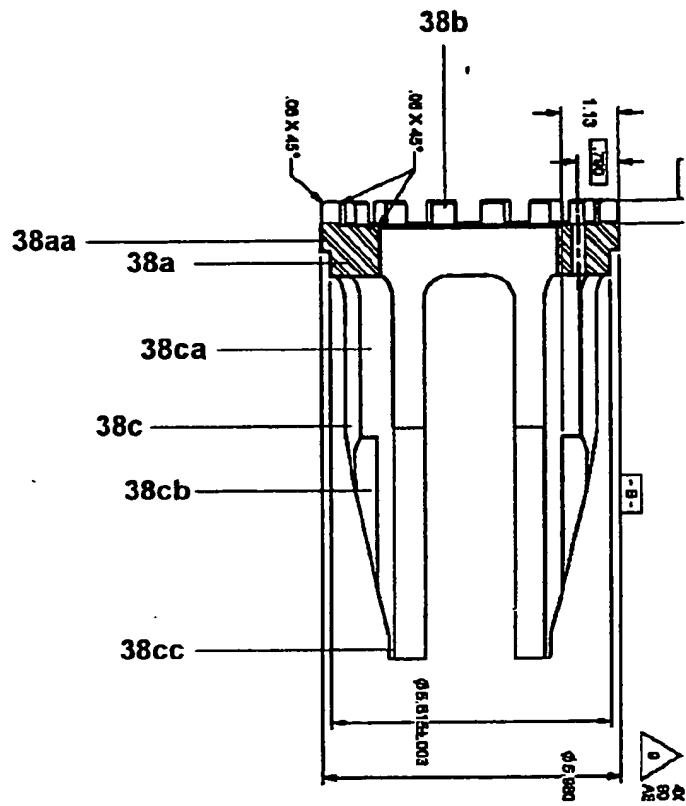

FIG. 7d

38  
↙

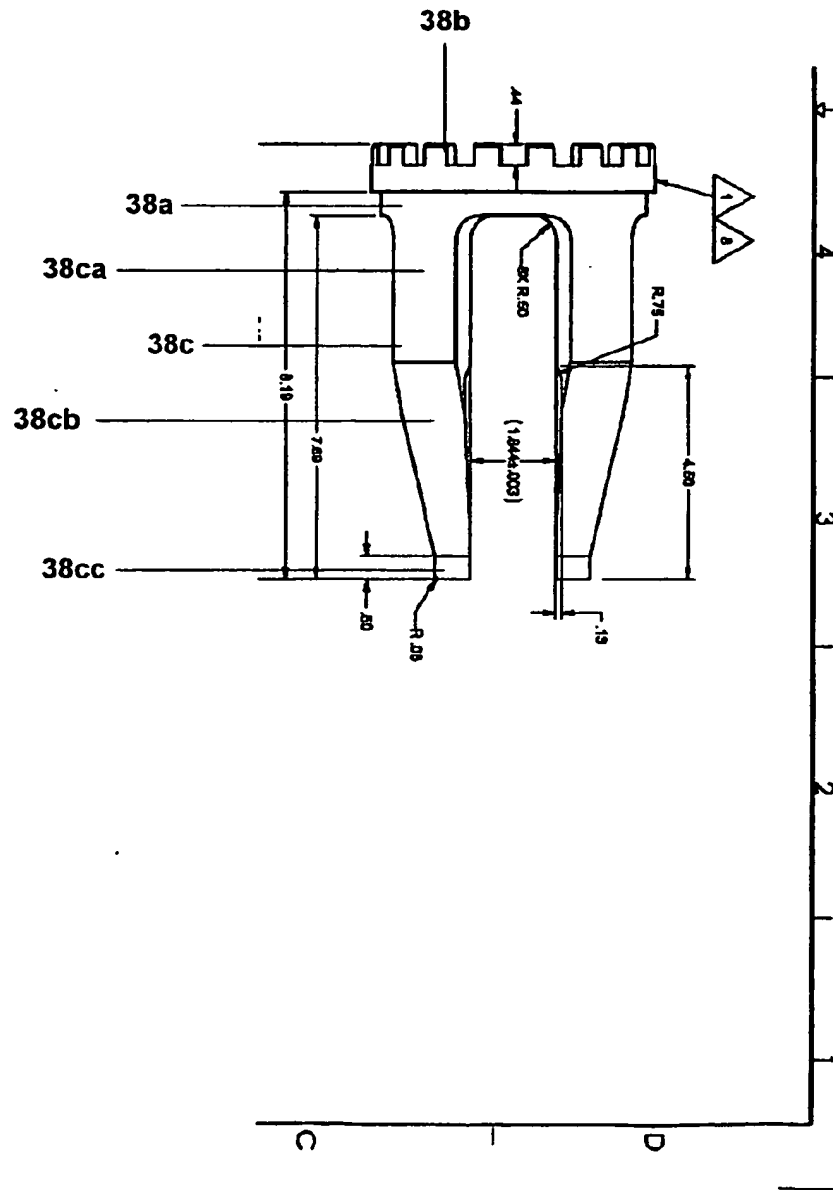

FIG. 7e

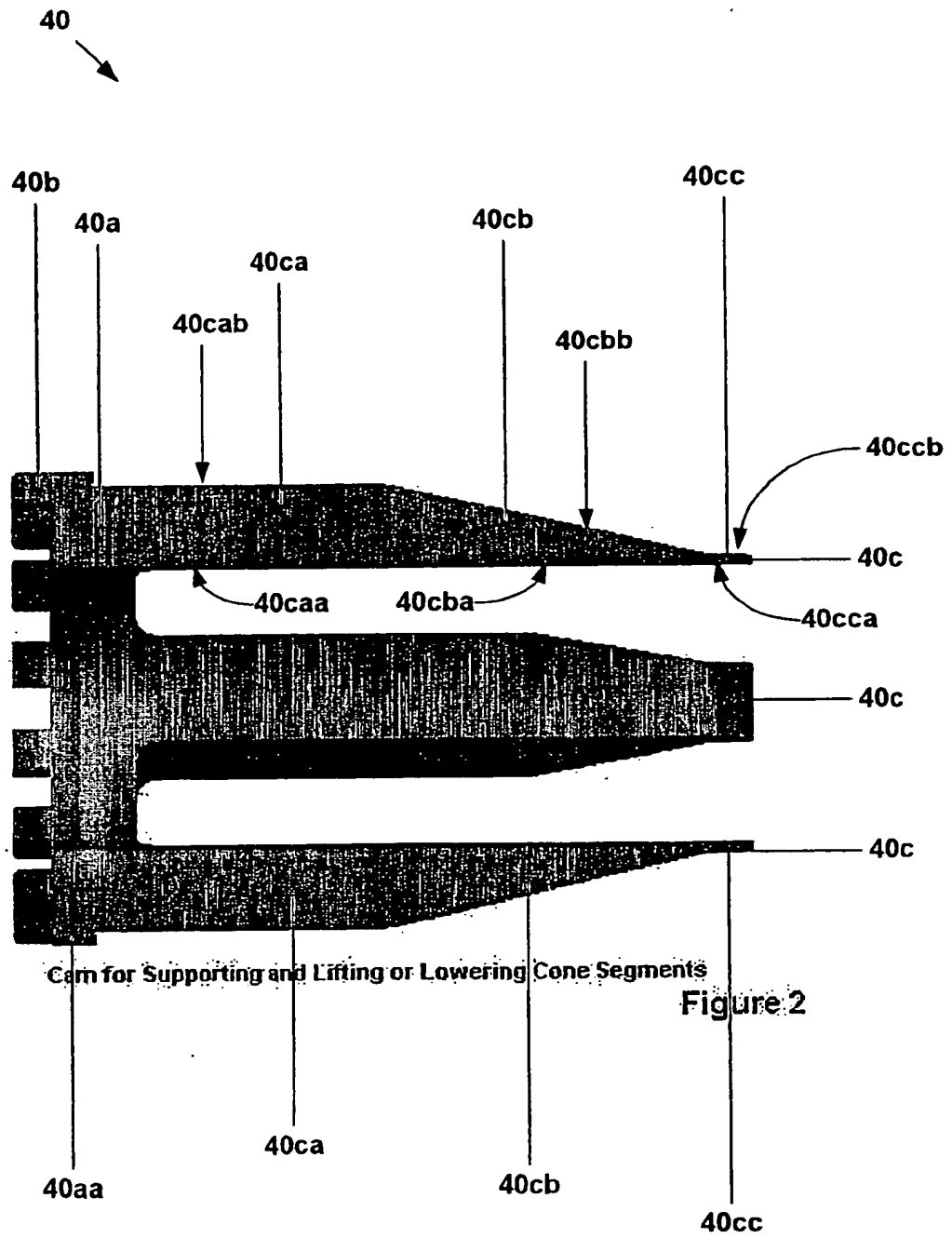

FIG. 7f

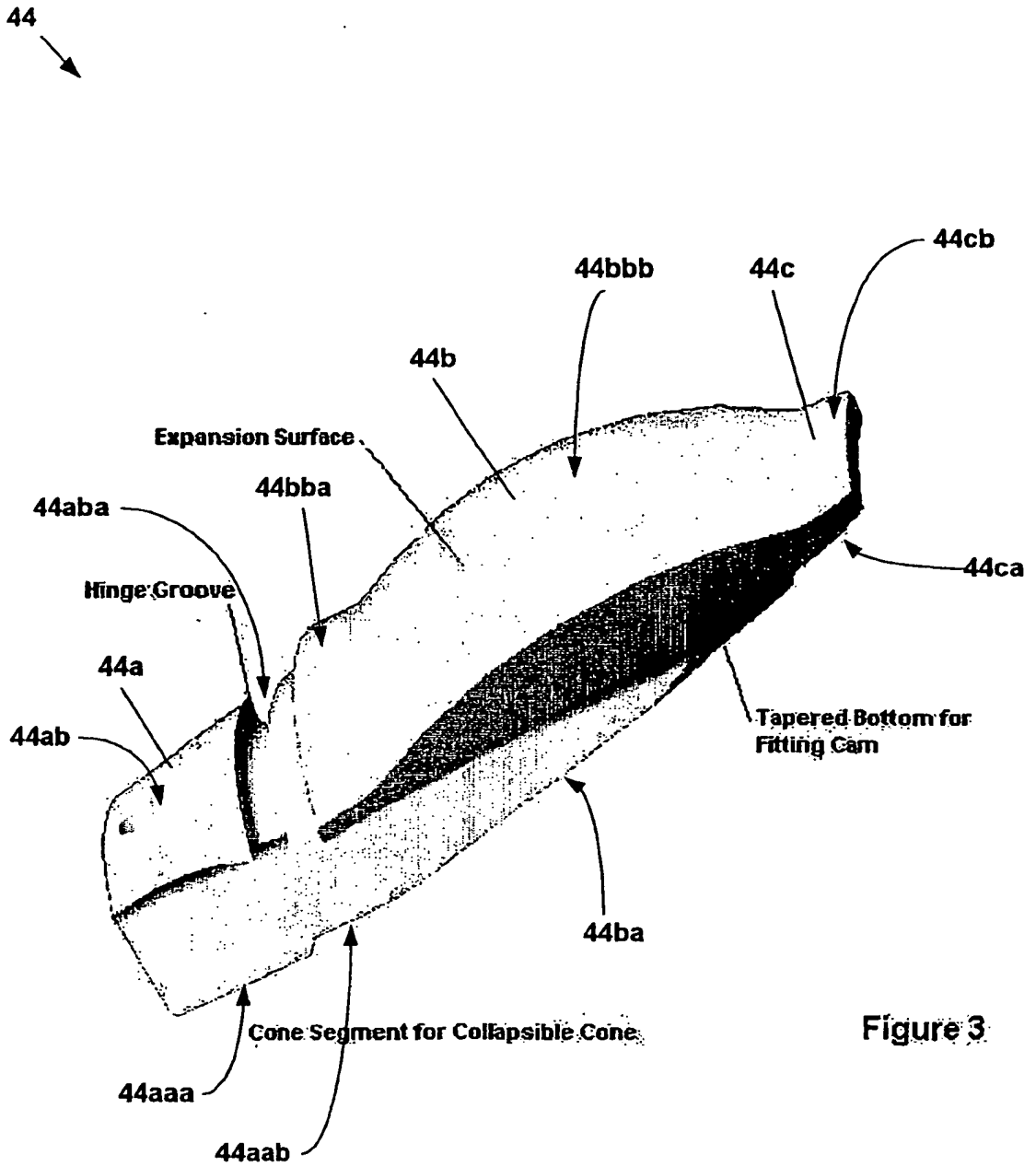

FIG. 8a

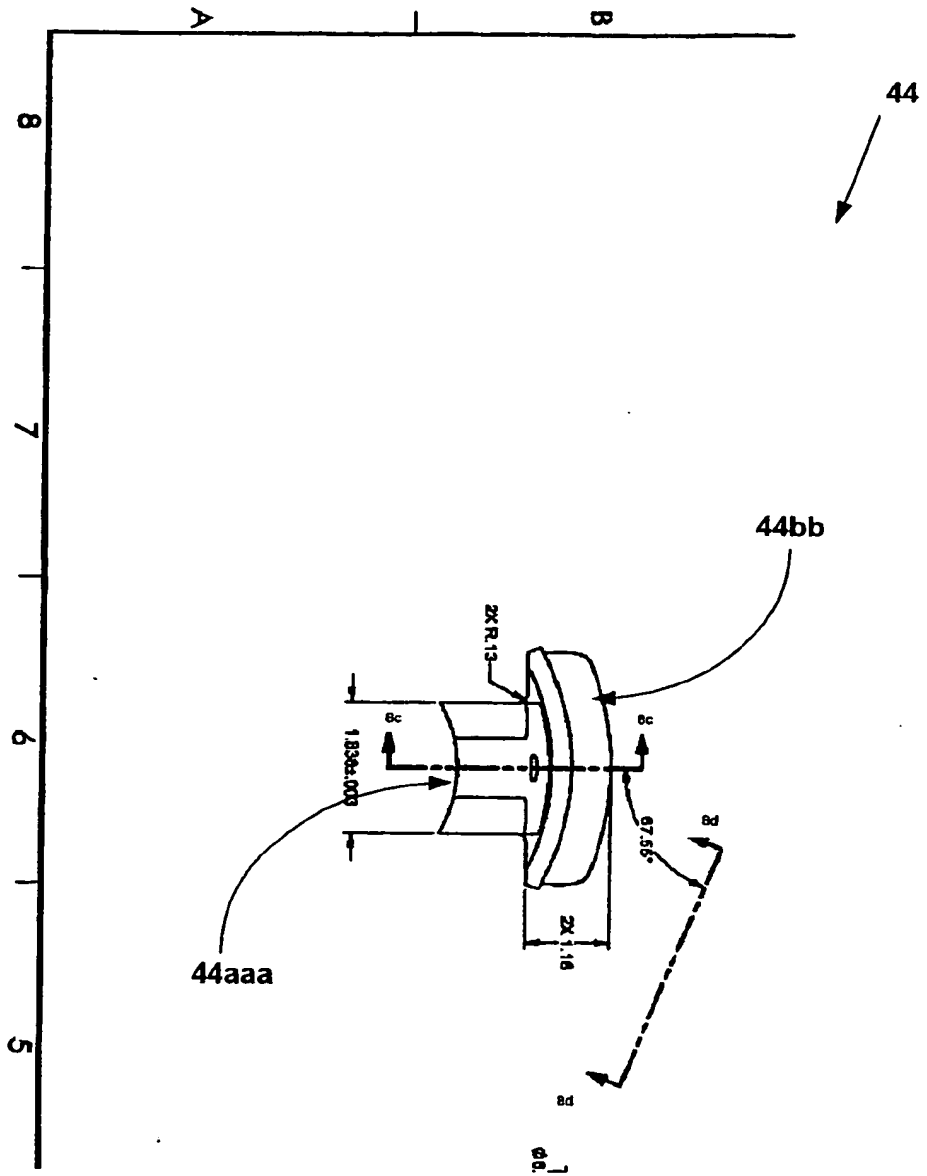

FIG. 8b

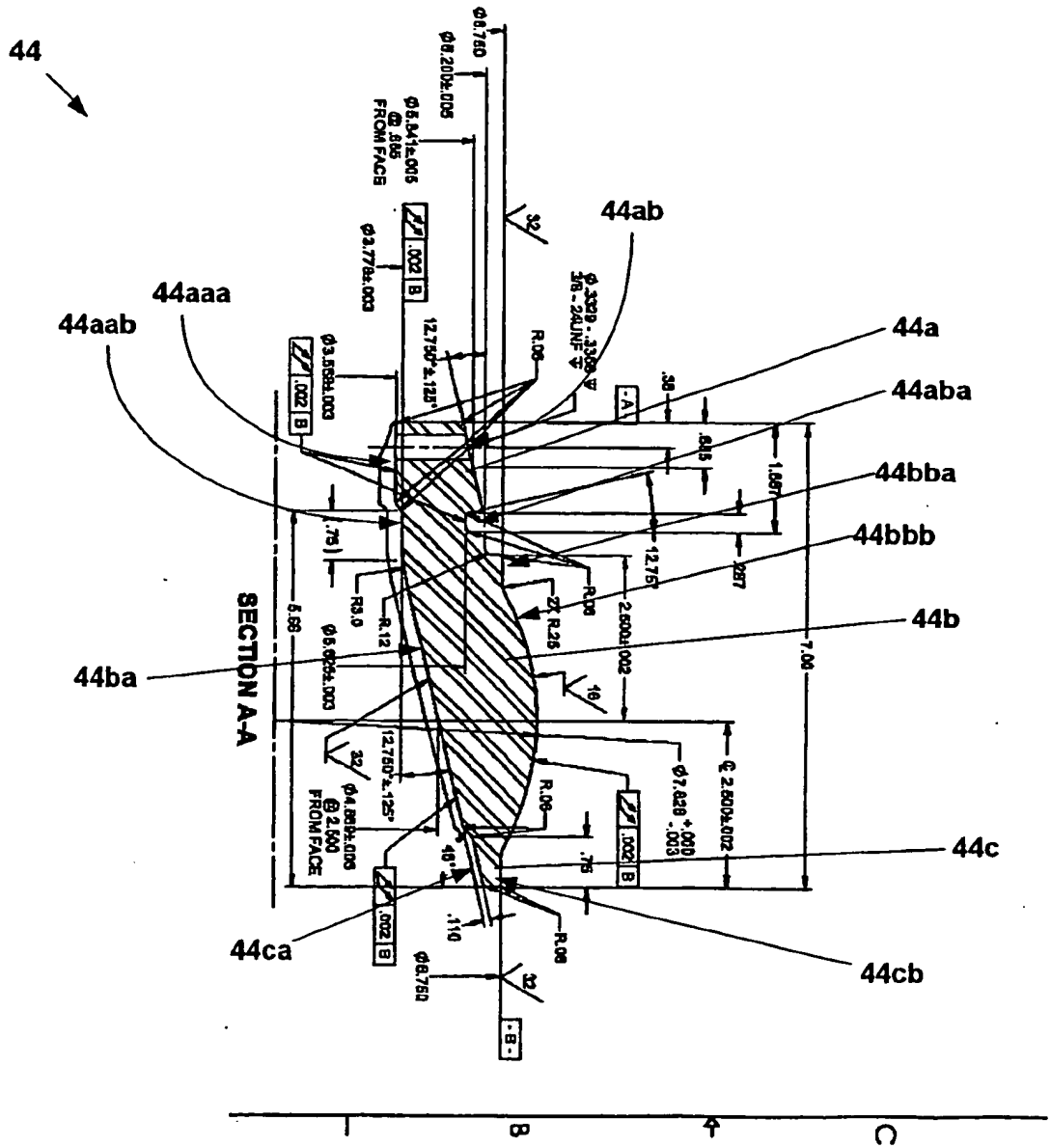

FIG. 8c

44  
↓

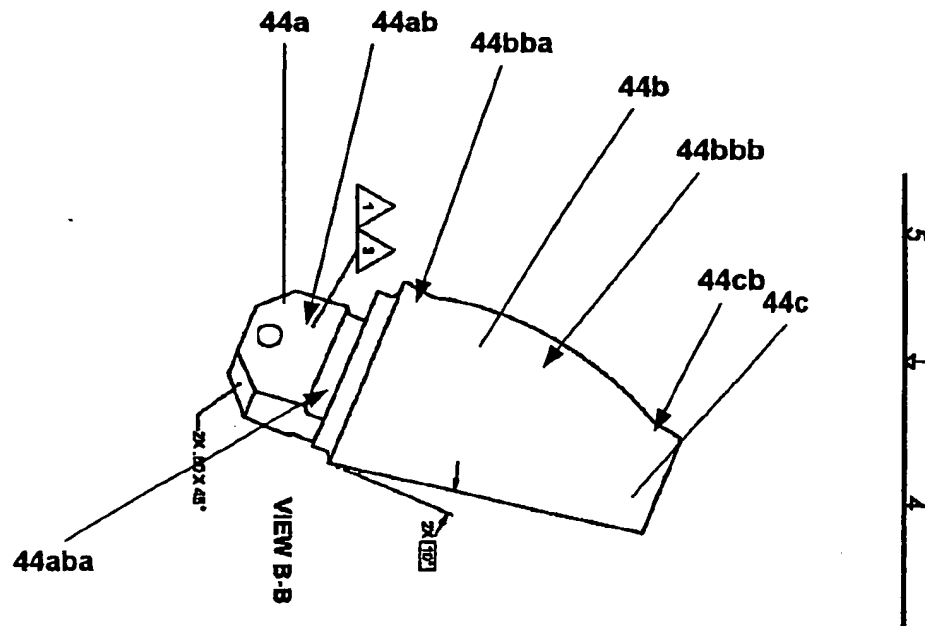

FIG. 8d

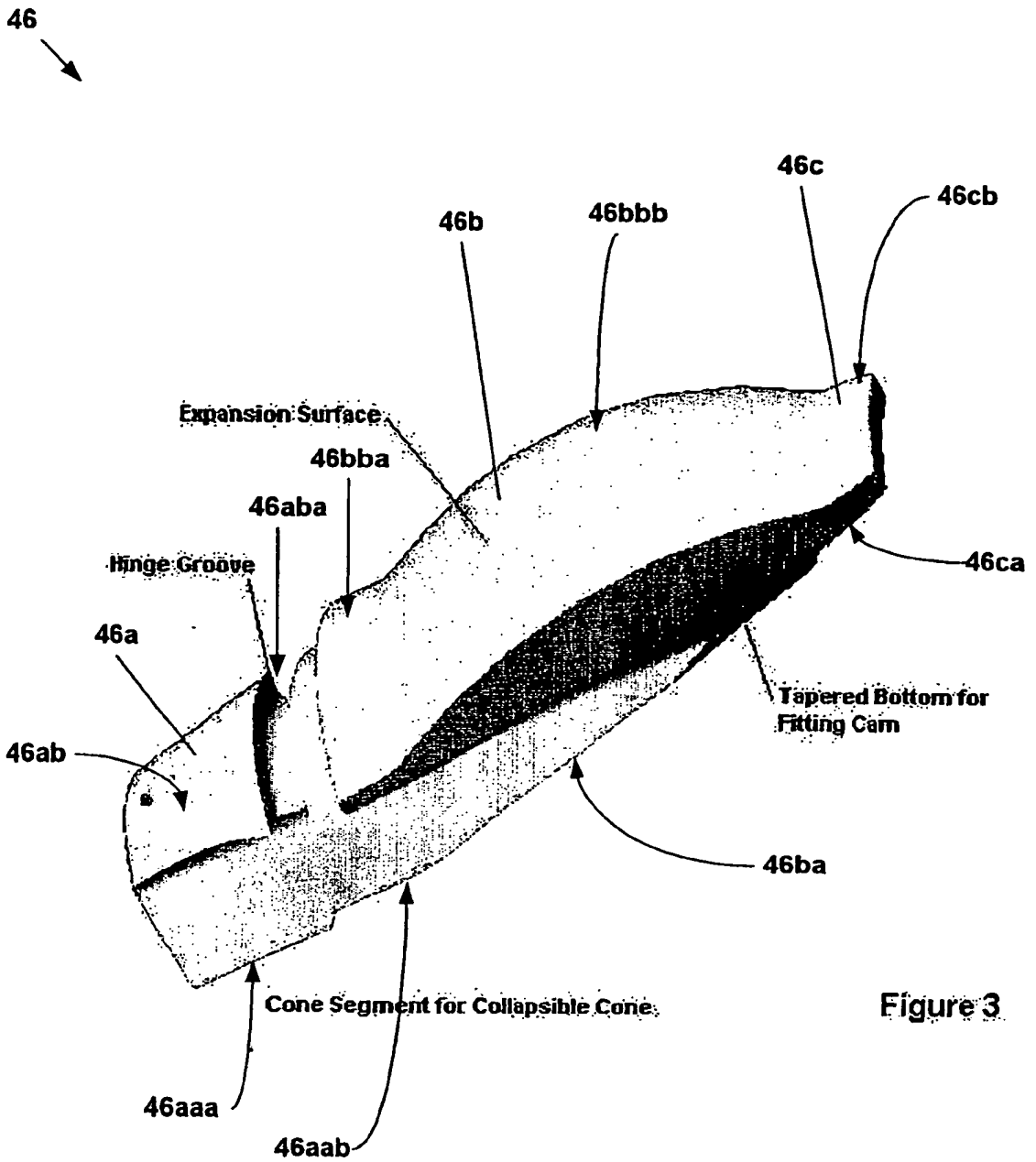

FIG. 8e



10  
↙

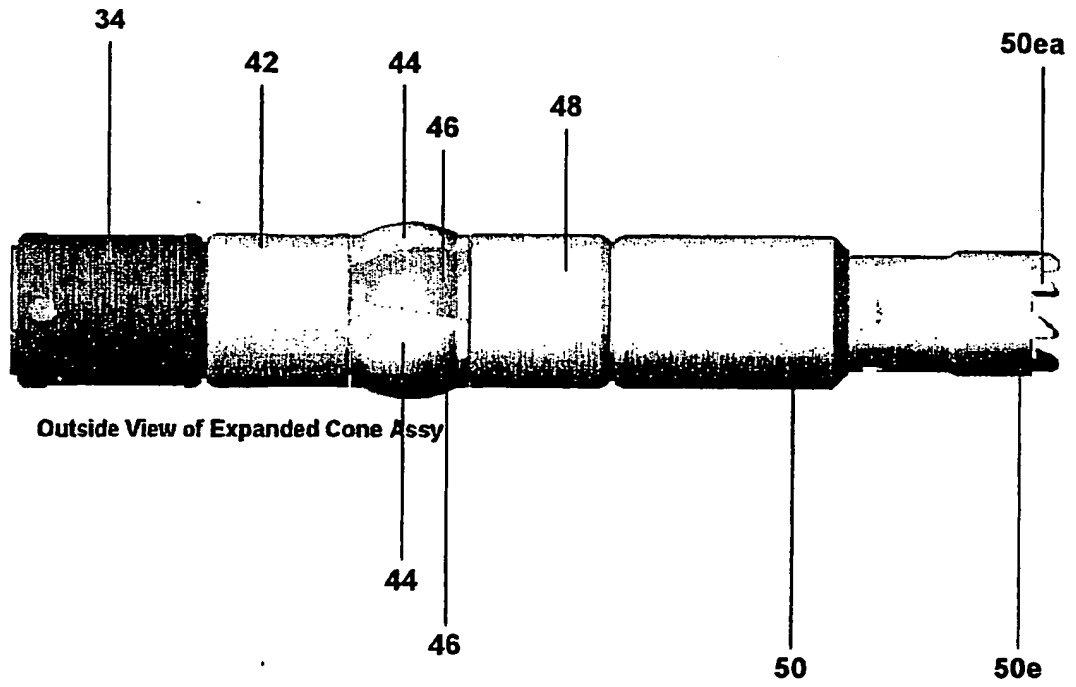

FIG. 9

10  
↙

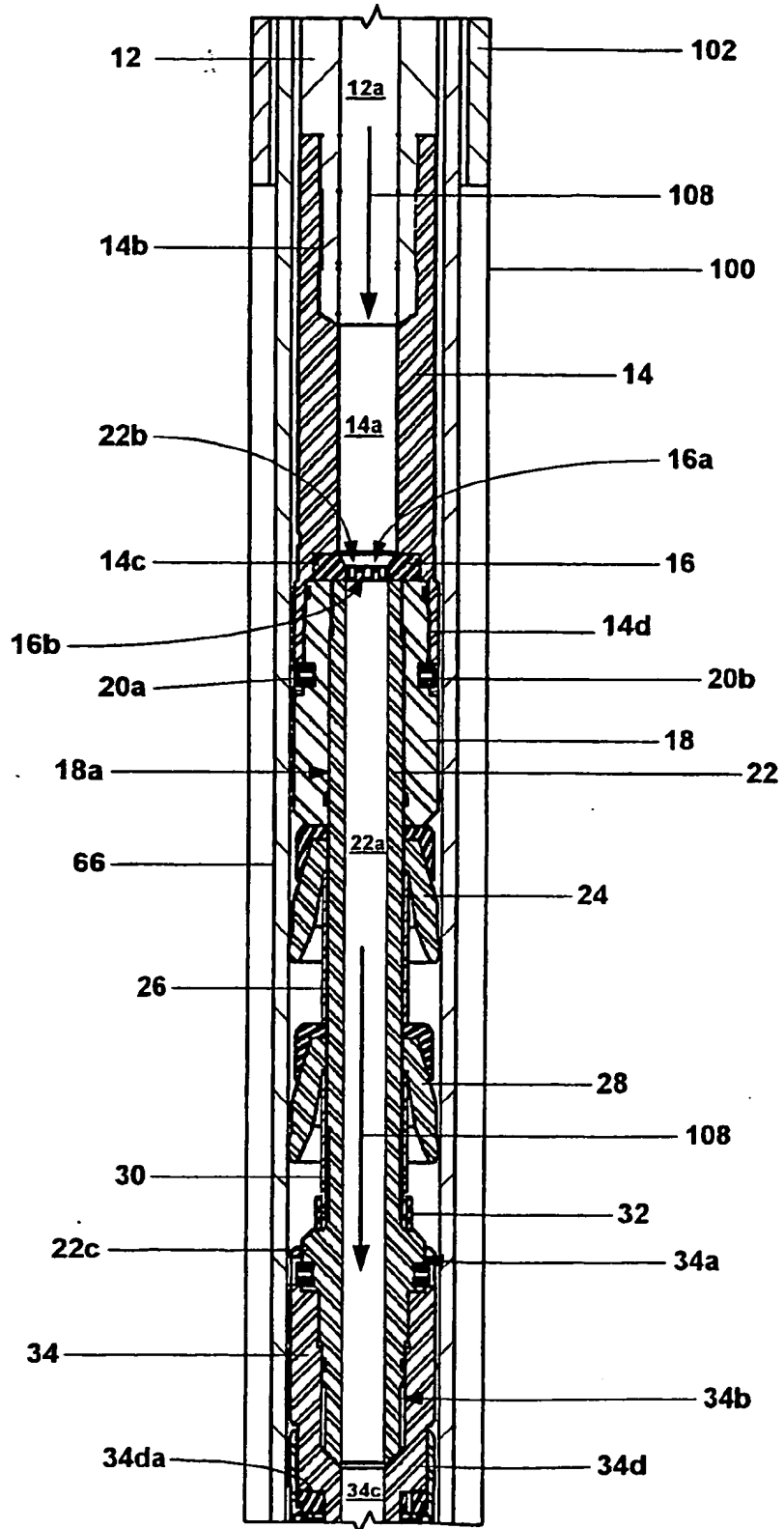

FIG. 10a

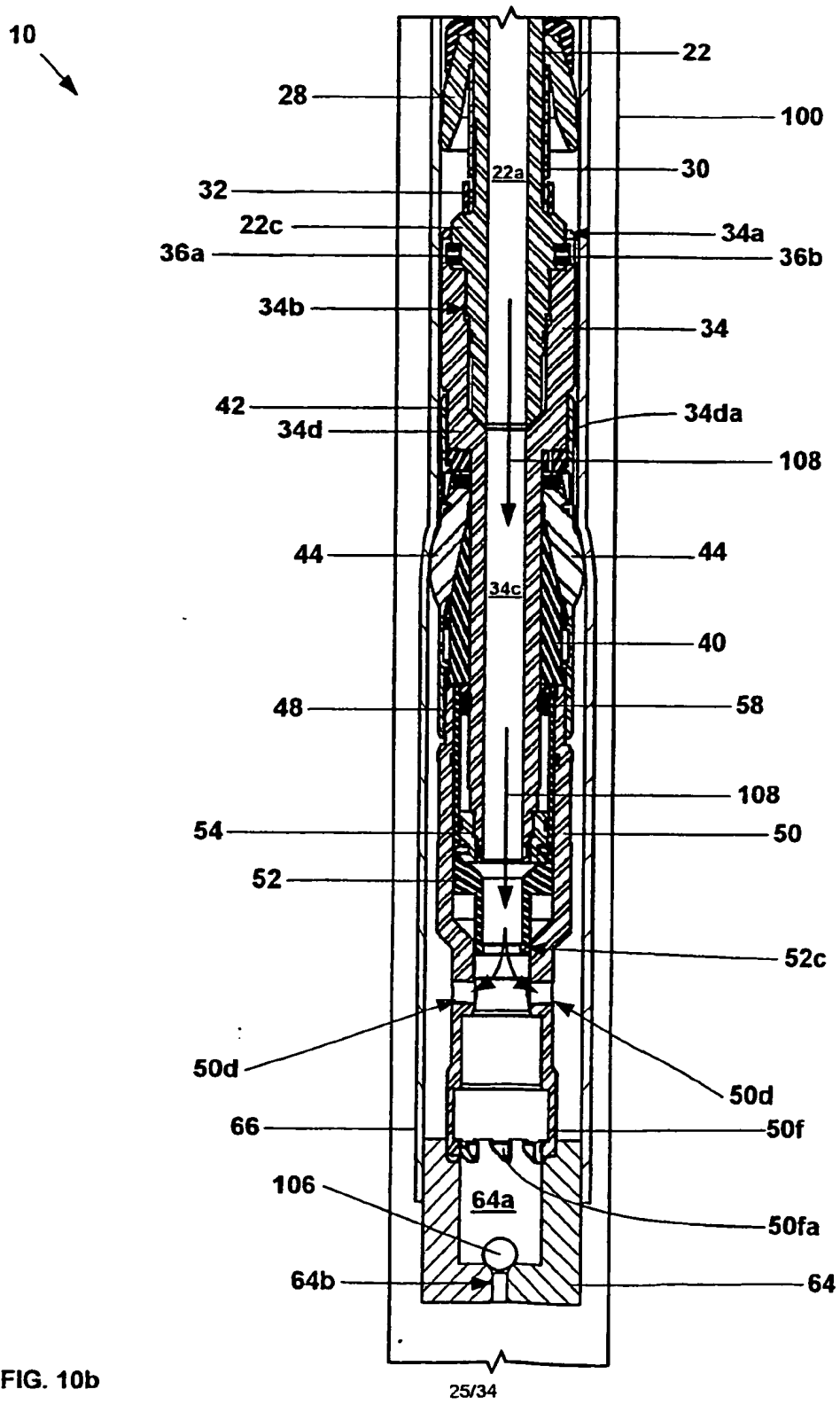

FIG. 10b

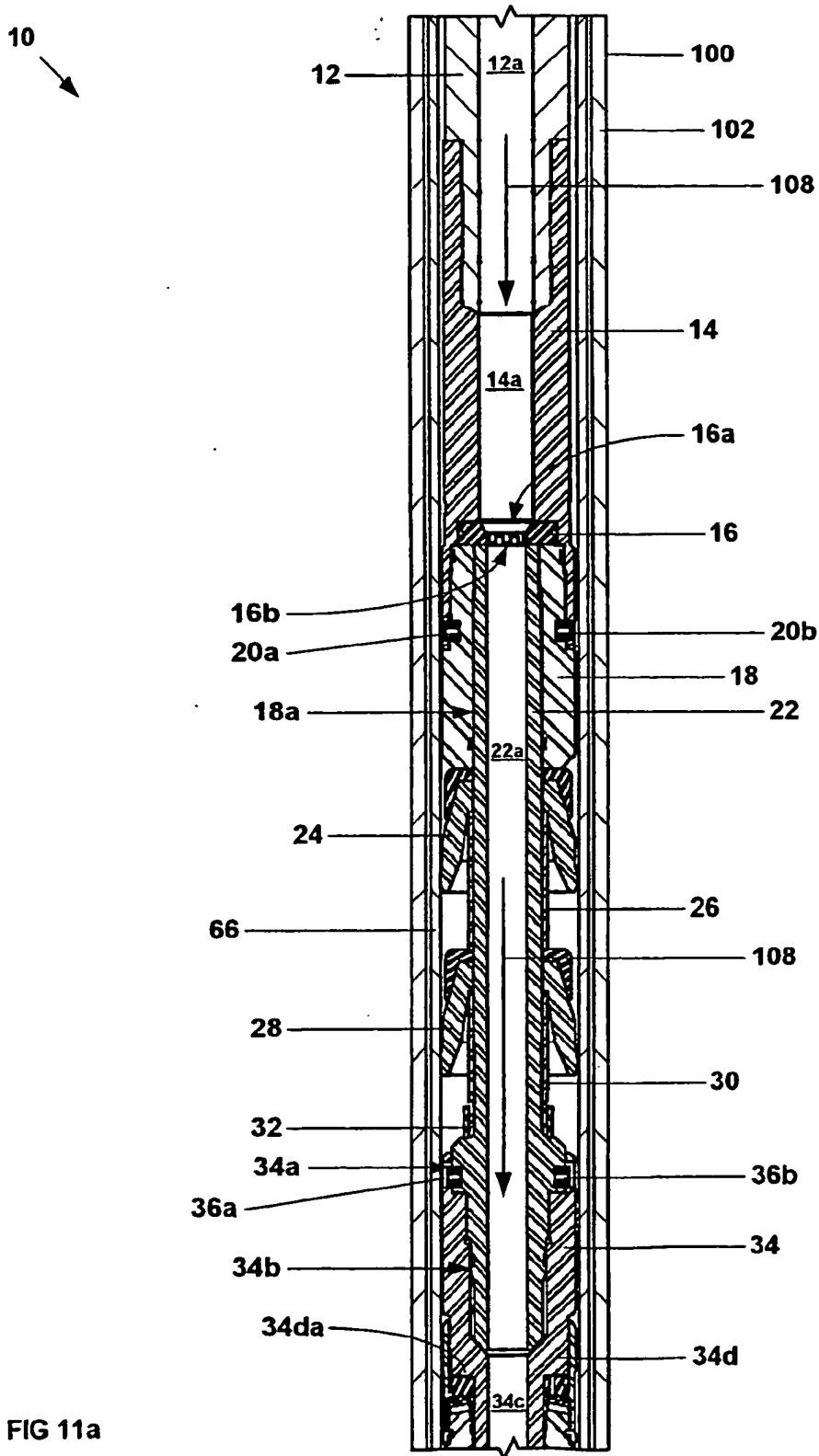

FIG 11a

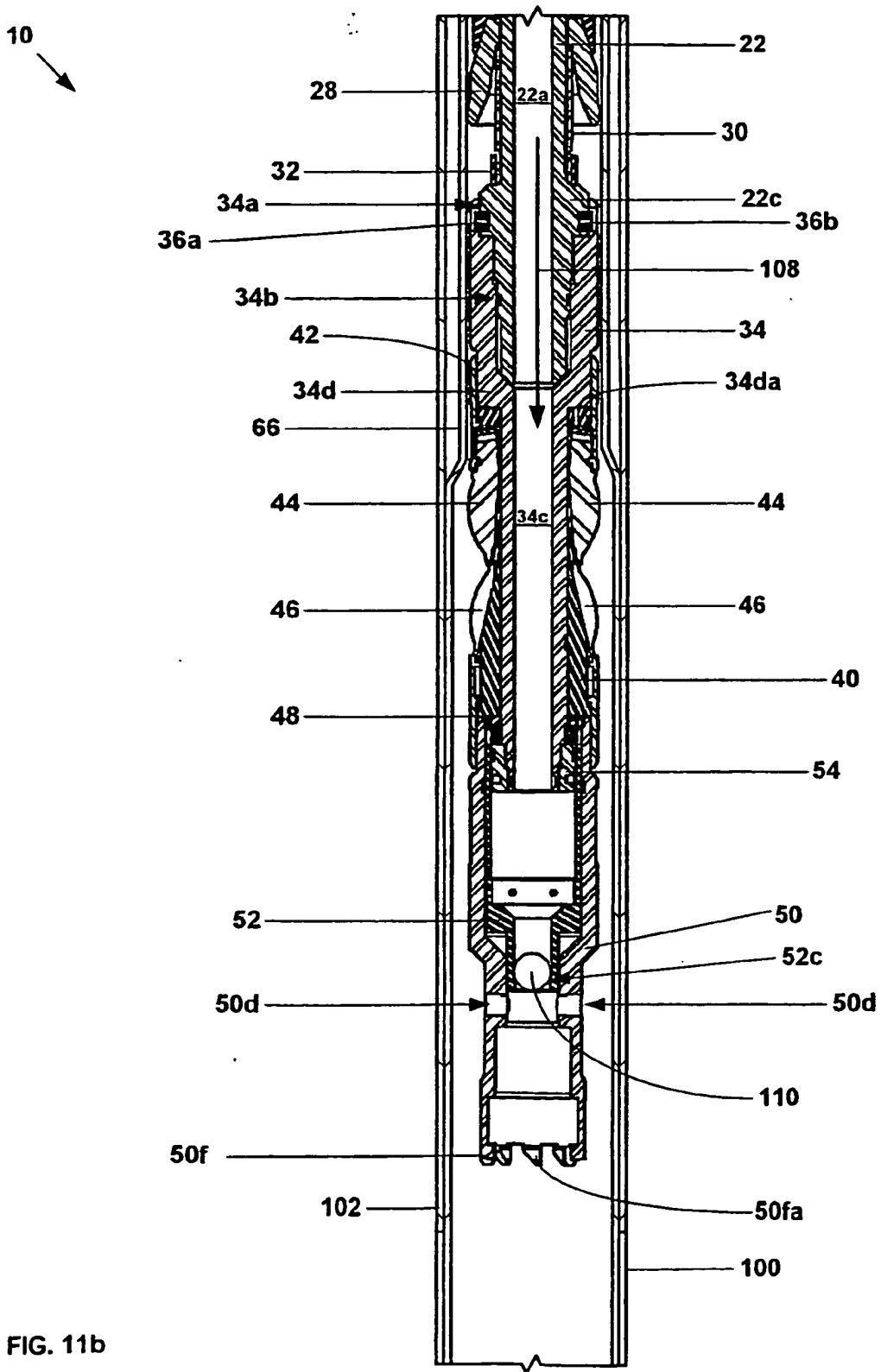

FIG. 11b

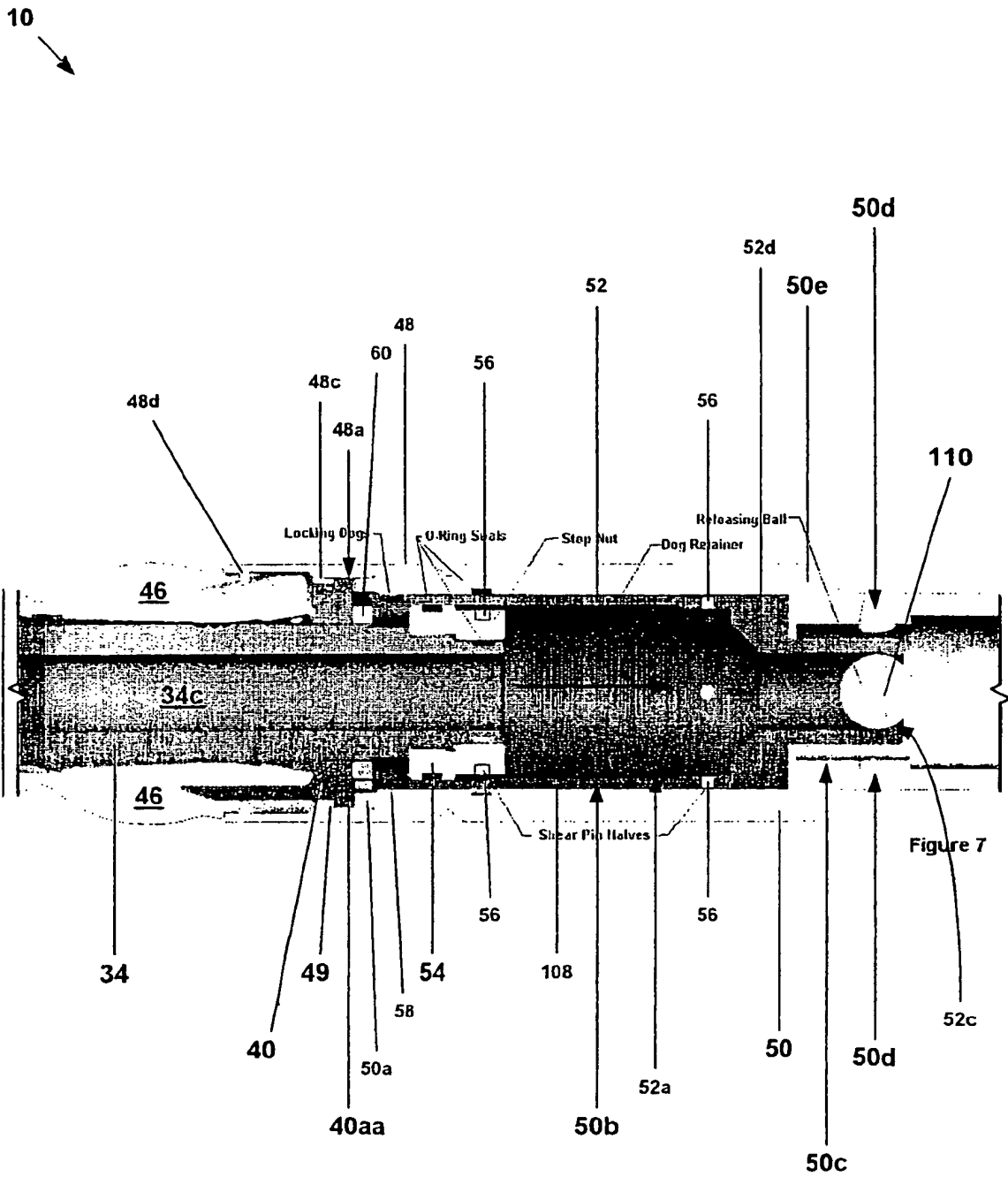

FIG. 12

10

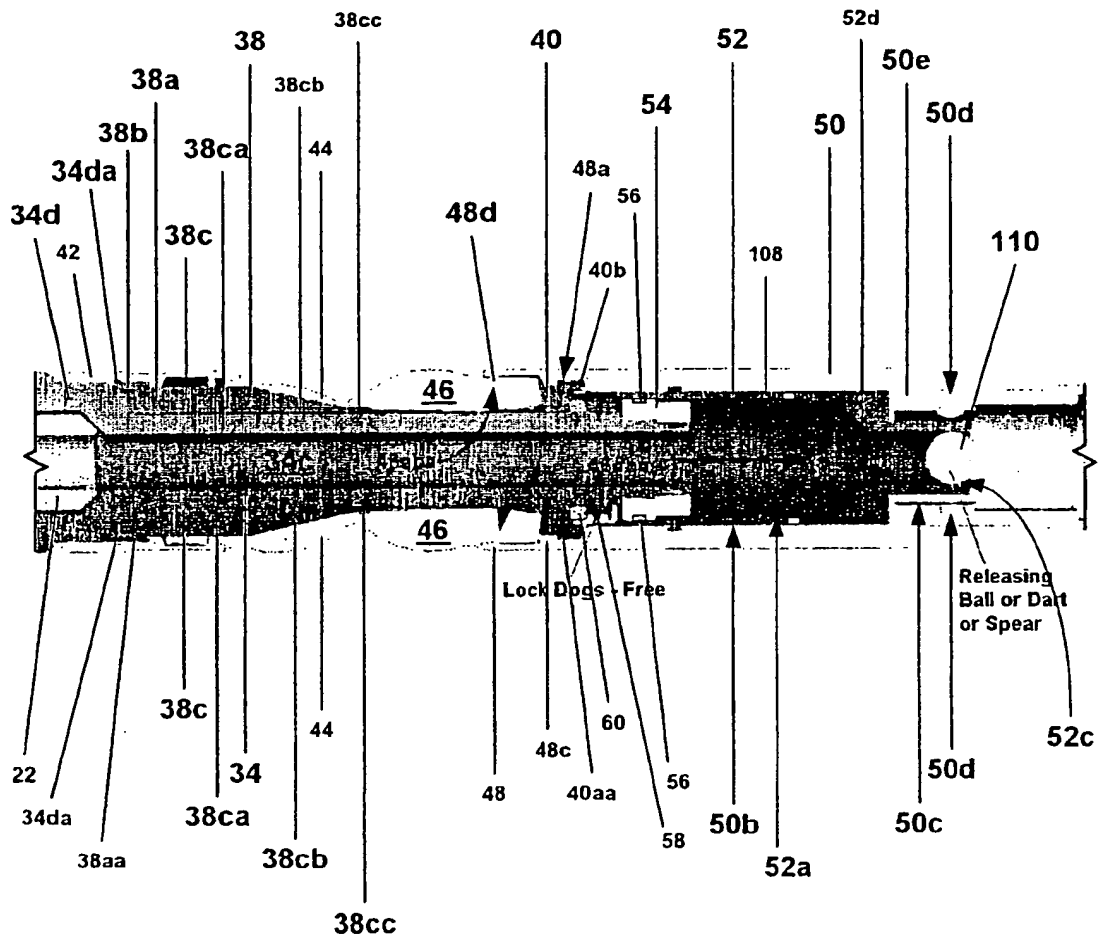

FIG. 13

10

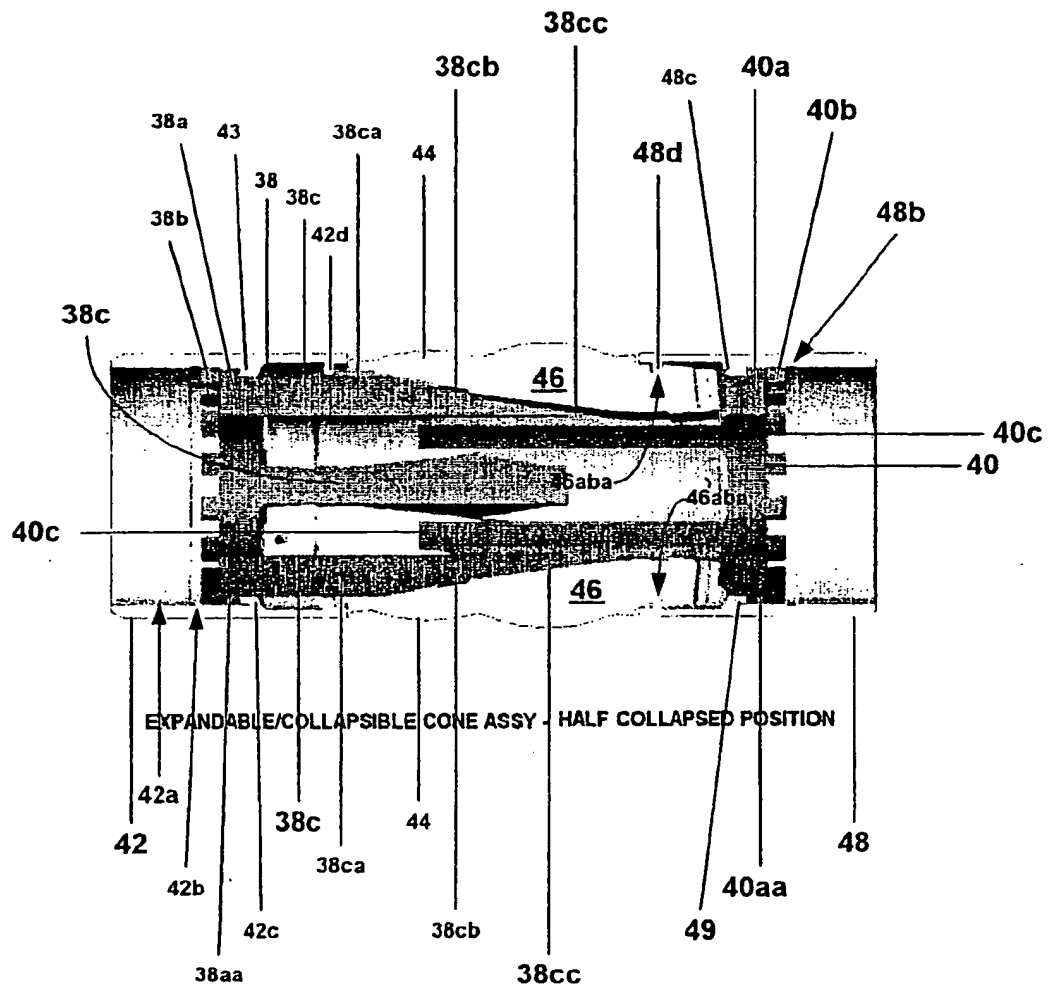
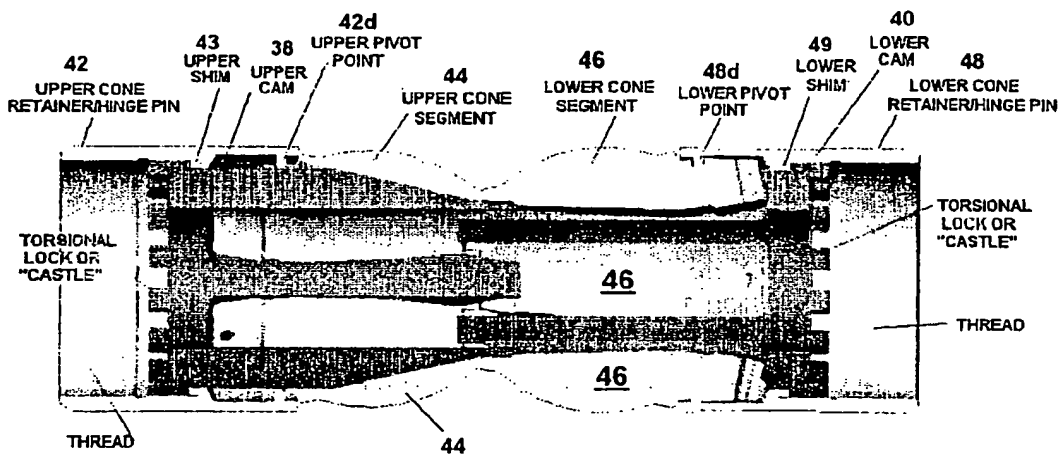

FIG. 14



10  
↙



EXPANDABLE/COLLAPSIBLE CONE ASSY - FULL COLLAPSED POSITION

FIG. 15

10  
↙

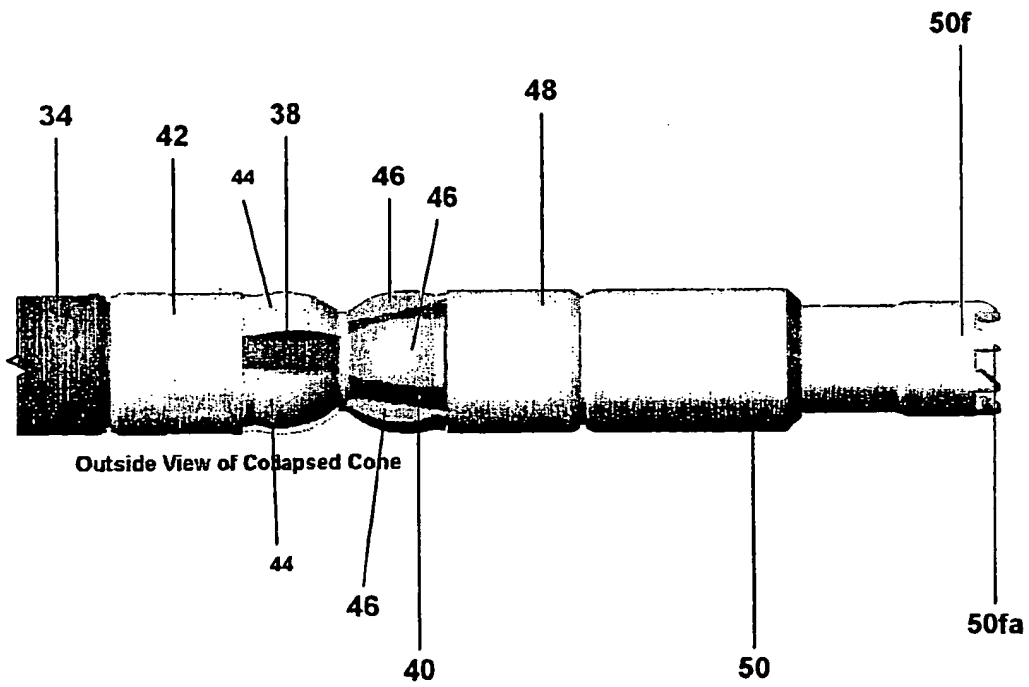

FIG. 16

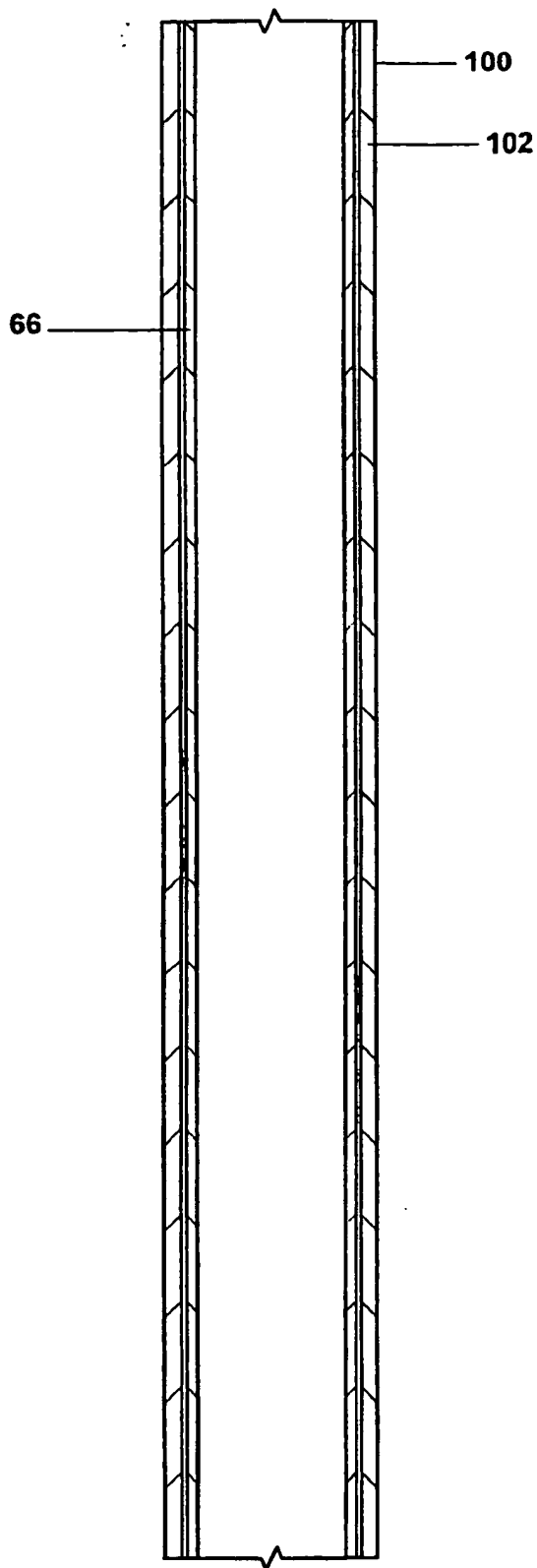

FIG 17a

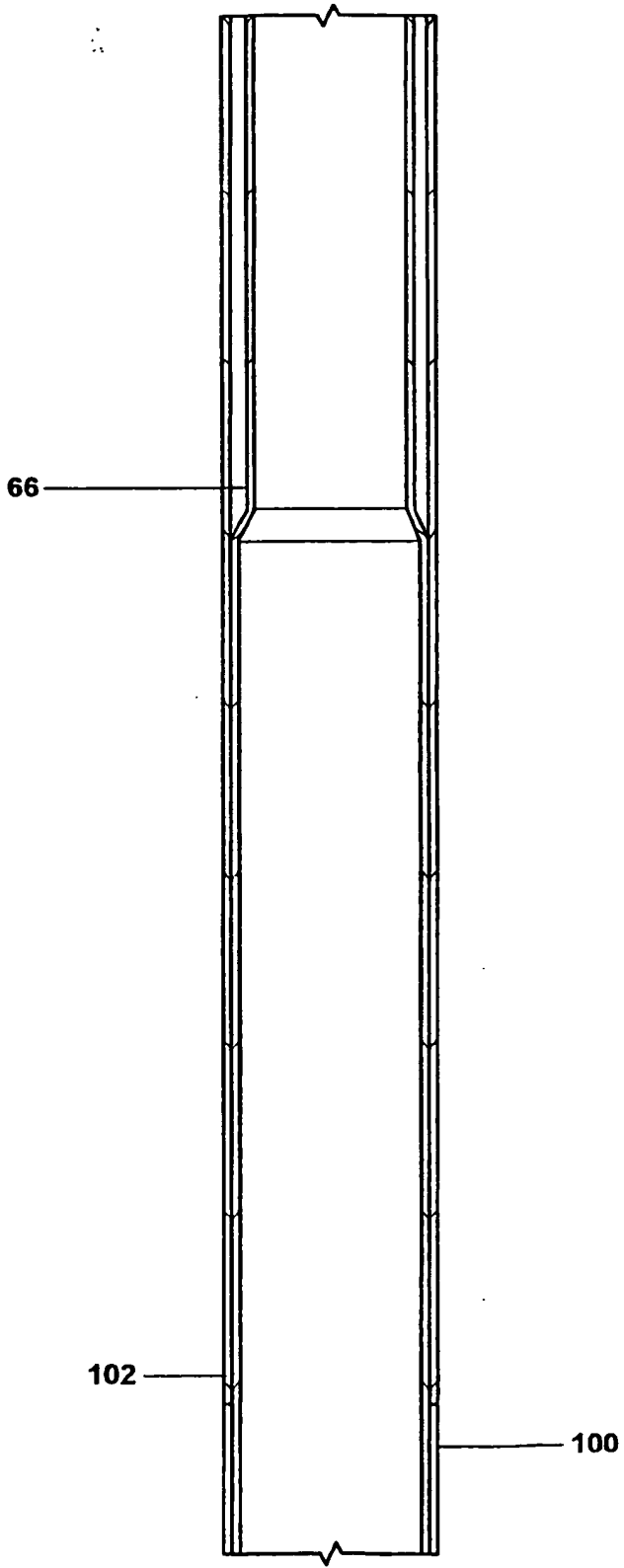

FIG. 17b